

Owner's Manual

- June, 1996 -

- Freestanding Direct-Vent Stove
- Natural Gas or Propane
- Residential or Mobile Home

ANSI Z21.44, Z21.11.4
CAN/CGA 1-2.19-M81, IR41, IR55, 2.17-M91

WARNING: If the information in this manual is not followed exactly, a fire or explosion may result causing property damage, personal injury or loss of life.

- Do not store or use gasoline or other flammable vapors and liquids in the vicinity of this or any other appliance.
- **WHAT TO DO IF YOU SMELL GAS**
 - Do not try to light any appliance.
 - Do not touch any electrical switch; do not use any phone in your building.
 - Immediately call gas supplier from a neighbor's phone. Follow the gas supplier's instructions.
 - If you cannot reach your gas supplier, call the fire department.
- Installation and service must be performed by a qualified installer, service agency or the gas supplier.

Heritage Bay Gas Stove

 **Travis Industries, Inc.**
10850 117th Place N.E. Kirkland, WA 98033

 **OMNI** Listed

AS:

pliance

open flame

any electrical switch or plug or unplug anything

ows and vacate building

supplier from neighbor's house, if not reached, call fire d

This unit must be installed by a qualified installer to prevent the possibility of an explosion. Your dealer will know the requirements in your area and can inform you of those people considered qualified. The room heater should be inspected before use and at least annually by a qualified service person. More frequent cleaning may be required due to excessive lint from carpeting, bedding material, etc.

- The instructions in this manual must be strictly adhered to. Do not use makeshift methods or compromise in the installation. Improper installation will void the warranty and safety listing.

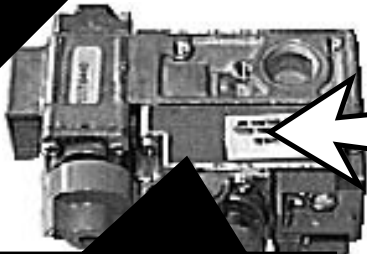

THIS CONTROL HAS BEEN CONVERTED FOR NATURAL GAS

THIS CONTROL HAS BEEN CONVERTED TO LP

- This heater is either approved for natural gas (NG) or propane (LP). Burning the incorrect fuel will void the warranty and safety listing and may cause an extreme safety hazard. Check the label above the gas control valve to make sure it matches the fuel being used. Direct questions about the type of fuel used to your dealer.



...to
...nt and
...n on any
...ion restrictions or
...ction requirements in
...ea. Notify your
...e company of this
...ell.



- If the flame becomes sooty, dark orange in color, or extremely tall, do not operate the heater. Call your dealer and arrange for proper servicing.

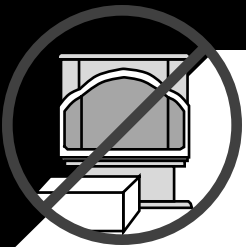

...ve that
...ontrol compartments,
...creens, or circulating air
...passageways of the heater
...be kept clean and free of
...obstructions. These areas
...provide the air necessary
...for safe operation.

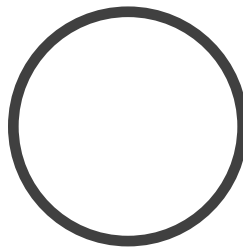

- Do not operate the heater if it is not operating properly in any fashion or if you are uncertain. Call your dealer for a full explanation of your heater and what to expect.



- Do not store or use gasoline or other flammable liquids in the vicinity of this heater.
- Keep all furniture or other combustible items at least 36" away from the front of the heater.



- Do not operate if any portion of the heater was submerged in water or if any corrosion occurs.



- Do not place clothing or other flammable items on or near the heater. Because this heater can be controlled by a thermostat there is a possibility of the heater turning on and igniting any items placed on or near it.

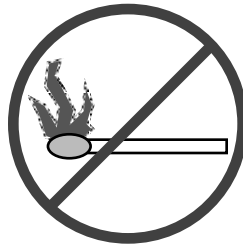

- Light the heater using the built-in piezo igniter. Do not use matches or any other external device to light your heater.



- The viewing glass should be opened for service only (see the maintenance section of this manual).

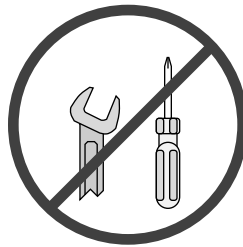

- Never remove, replace, modify or substitute any part of the heater unless instructions are given in this manual. All other work must be done by a trained technician. Don't modify or replace orifices.



- Any safety screen or guard removed for servicing must be replaced prior to operating the heater.

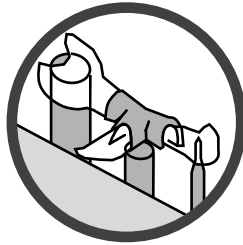

- Allow the heater to cool before carrying out any maintenance or cleaning.

- Operate the heater according to the instructions included in this manual.
- If the main burners do not start correctly turn the gas off at the gas control valve and call your dealer for service.

- The pilot flame must contact the thermopile and thermocouple (see the illustration to the left). If it does not, turn the gas control valve to "OFF" and call your dealer.



- This unit is not for use with solid fuel
- Do not place anything inside the firebox (except the included fiber logs).
- If the fiber logs become damaged, replace with Travis Industries log set.



- Do not throw this manual away. This manual has important operating and maintenance instructions that you will need at a later time. Always follow the instructions in this manual.



- Do not touch the hot surfaces of the heater. Educate all children of the danger of a high-temperature heater. Young children should be supervised when they are in the same room as the heater.

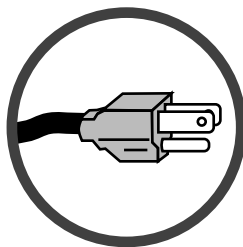

- Plug the heater into a 120V grounded electrical outlet. Do not remove the grounding plug.
- Don't route the electrical cord in front of, over, or under the heater

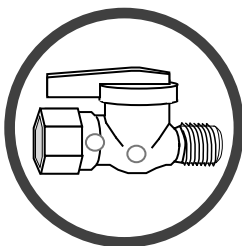

- Instruct everyone in the house how to shut gas off to the appliance and at the gas main shutoff valve. The gas main shutoff valve is usually next to the gas meter or propane tank and requires a wrench to shut off.



- Travis Industries, Inc. grants no warranty, implied or stated, for the installation or maintenance of your heater, and assumes no responsibility of any consequential damage(s).**

Introduction & Important Info. 1

Safety Precautions 2

Features & Specifications 5

Installation Options 5

Heating Specifications 5

Dimensions 5

Fuel, Emissions, Electrical 5

Stove Installation

Installation Preparation 6

Items Required for Installation 6

Items Packed with the Heritage Bay 6

Order of Installation 6

Stove Clearances 6

Stove Placement Requirements 7

Floor Protection Requirements 7

Gas Line Installation 7

Vent Requirements 8

Approved Vent Configurations 9

Restrictor Position 9

Elbows 9

Measuring Vent Lengths 9

Approved Vent Config's with No Elbows
or Two 45° Offsets (Vertical Term.) 10

Approved Vent Config's with a
Horizontal Termination 11

Approved Vent Config's with a Vertical
Termination and Two 90° Elbows 12

Horizontal Vent Termination Requirements 13

Vertical Vent Termination Requirements 13

Electrical Connection 13

Finalizing the Installation

Burner Pan Installation 14

Door Opening 15

Log, Twig, and Ember Installation 17

Leak Test the Gas Line 18

Pilot Flame Inspection 18

Air Shutter Adjustment 18

Flame Inspection 18

Explain Heater Operation to Owner 18

Operating Your Heater

Before You Begin 19

Location of Controls 19

Starting The Pilot Flame 20

Starting the Heater for the First Time 21

Turning the Heater On and Off 21

Adjusting the Flame Height 21

Adjusting the Blower Speed 22

Normal Operating Sounds 22

Maintaining Your Heater

Cleaning Your Heater 23

Yearly Service Procedure 23

Adjusting the Door 24

Troubleshooting

Troubleshooting Table 25

How this Heater Works 26

Wiring Diagram 27

Warranty 28

Listing Information 29

Optional Equipment

Thermostat Installation 30

Remote Control Thermostat 31

Addendum

Altitude Considerations 33

Class A Chimney Conversion Kit 33

Index 34

Symbols Used in this Manual

The illustration below details what the symbols used along the left margin indicate.



Installation Options:

- Freestanding
- Residential or Mobile Home
- Horizontal or Vertical Vent
- Class A Chimney Retrofit

Features:

- Works During Power Outages (millivolt system)
- High Efficiency; Up to 79% for Natural Gas, 80% for LP (Steady State)
- Optional Thermostat or Remote Control
- Realistic "Wood Fire" Look
- Convenient Operating Controls
- Variable-Rate Heat Output
- Quiet Blower for Effective Heat Distribution
- Low Maintenance

Heating Specifications:

	Natural Gas	LP (Propane)
Approximate Heating Capacity (in square feet)*	1,200 - 2,000	1,200 - 2,000
High Burn Input Rate (In BTU's)	40,000	40,000
Low Burn Input Rate (In BTU's)	23,700	23,000
Efficiency**	79%	80%
AFUE (Annual Fuel Utilization Efficiency)	71%	72%

* Heating capacity will vary with the home's floor plan and insulation, natural gas or Propane BTU rating, and outside temperature.

** Efficiency rating is a product of thermal efficiency rating determined under continuous operation independent of installed system. To measure the net BTU's, multiply the BTU input by the efficiency percentage (79% for natural gas, 80% for LP).

Dimensions:

Fuel:

The heater is designed either for natural gas or for propane. Check the sticker on the top of the gas control valve.

Emissions:

This unit has passed the ANSI emission standards for vented room heaters as tested by OMNI Environmental Services, Inc.

Electrical Specifications:

120 Volts, 1.3 Amps, 60 Hz (150 watts on high)

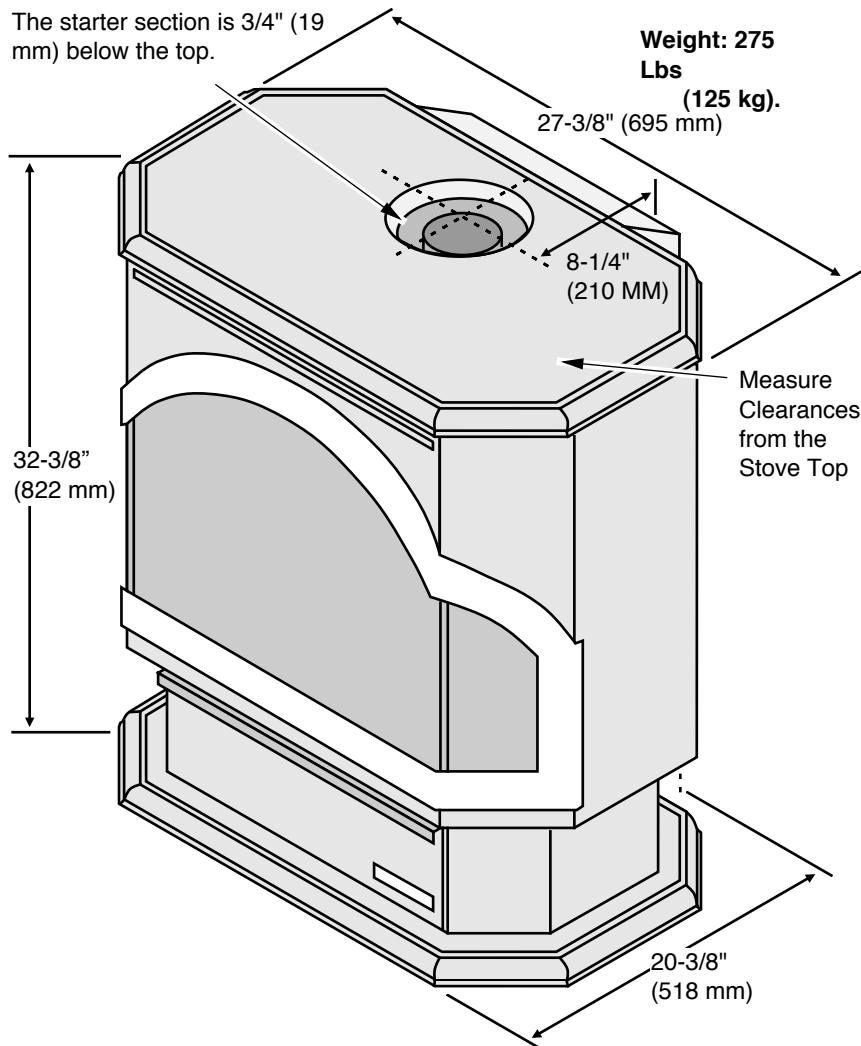

Installation Preparation

- ! Failure to follow all of the requirements may result in property damage, bodily injury, or even death.
- ! This appliance must be installed in accordance with all local codes, if any; if not, follow ANSI Z223.1 and NFPA 54(88).
- ! In Manufactured or Mobile Homes must confirm with: In USA, Manufactured Home Construction and Safety Standard, Title 24 CFR, Part 3280; In Canada, CSA Z240.4 and Gas-Equipped Recreational Vehicles and Mobile Housing. This appliance may be installed in Manufactured Housing only after the home is site located.
- ! This appliance is designed for natural gas or propane (LP). Check the sticker on top of the gas control valve.
- ! All exhaust gases must be vented outside the structure of the living-area. Combustion air is drawn from outside the living-area structure.
- ! Notify your insurance company before hooking up this appliance.
- ! The requirements below are divided into sections - all requirements must be met simultaneously.

Items Required for Installation

- Burner Pan (Natural Gas or Propane)
- Simpson Duravent (see page 8 for part #'s) & Silicone
- Gas Hookup Equipment

Items Packed with the Heritage Bay

- Heritage Bay (without Burner Pan)
- Flex Tube
- Log Set (2 Logs, 2 Twigs, Embers)

Order of Installation

- 1 Position the heater, use floor protection if needed
- 2 Connect the gas line. Connect the gas vent.
- 3 Follow the instructions under "Finalizing the Installation" on pages 14 through 18

Stove Clearances

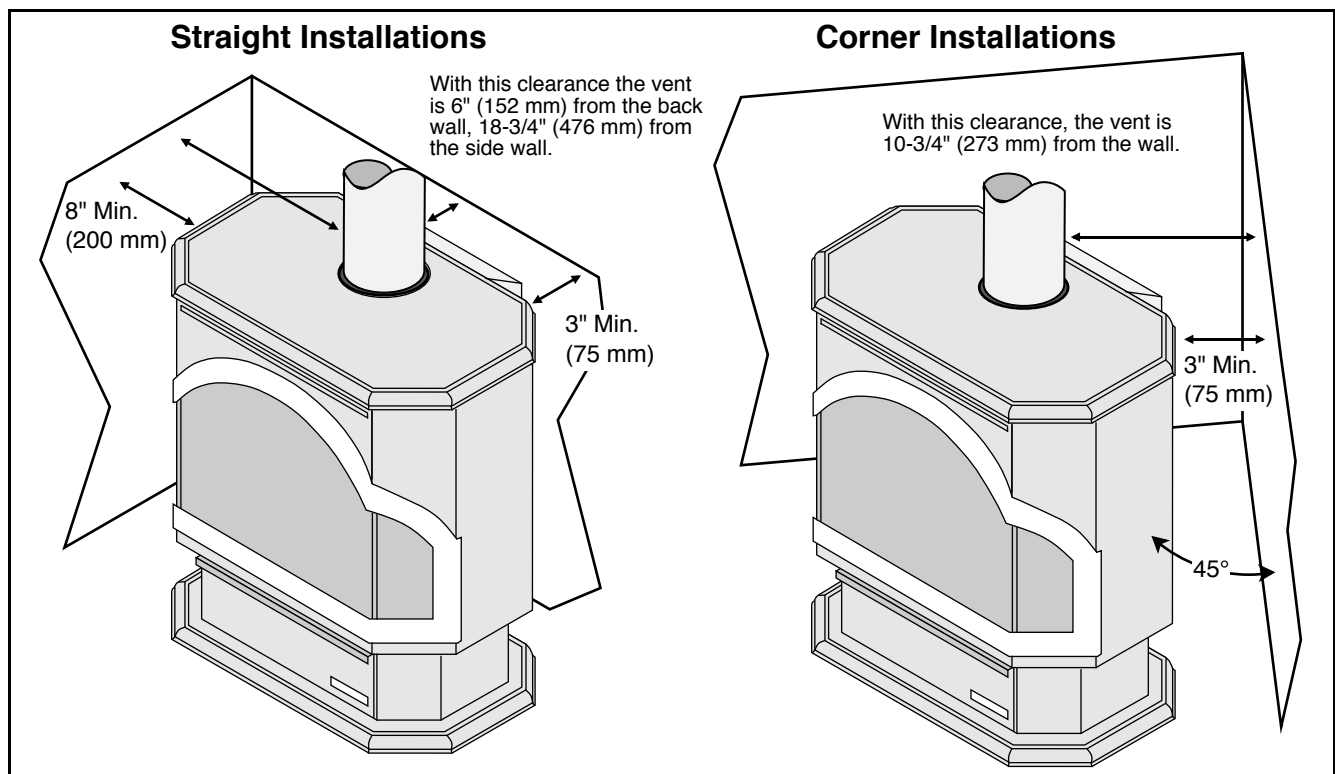

Heater Placement Requirements

- Heater must be installed on a level surface capable of supporting the heater and vent
- Due to the high temperature of the heater, it should be located out of traffic and away from furniture and draperies. Heater must be placed so no combustibles are within, or can swing within 36" (910 mm) of the front of the heater (e.g. drapes, doors)
- ? When placed in a location where the floor to ceiling height is under 7 feet (2130 mm), the installation is considered an alcove and must meet the following requirements:
 - The alcove floor to ceiling height must be at least 60" (1520 mm) tall
 - The alcove must not be more than 48" (1220 mm) deep before the ceiling returns to 7' (2130 mm)
 - The alcove must be at least 43-3/8" (1100 mm) wide
- The heater must not be placed so the vents below or above the door, along the sides of heater, or along the back of the heater can become blocked.

Floor Protection

- When the stove is installed directly on carpeting, vinyl or other combustible material other than wood flooring, the stove must be installed on a metal or wood protection panel extending the full width and depth of the heater (Minimum 27-3/8" (695 mm) wide by 20-3/8" (518 mm) deep).

Gas Line Installation

- ! The gas line must be installed in accordance with all local codes, if any; if not, follow ANSI Z223.1 and the requirements listed below.
- ! The heater and gas control valve must be disconnected from the gas supply piping during any pressure testing of that system at test pressures in excess of 1/2 psig (3.45 kPa). For pressures under 1/2 psig (3.45 kPa), isolate the gas supply piping by closing the manual shutoff valve.
- This heater is designed for natural gas but can be converted to propane. Check the sticker on the top of the gas control valve to make sure the correct fuel is used.
- Leak test all gas line joints and the gas control valve prior to and after starting the heater.
- The gas inlet accepts a 3/8" F.P.T. Fitting
- The location of the gas inlet is shown below
- A manual shutoff valve is required for installation (it must be located within 3' (910 mm) of the heater)

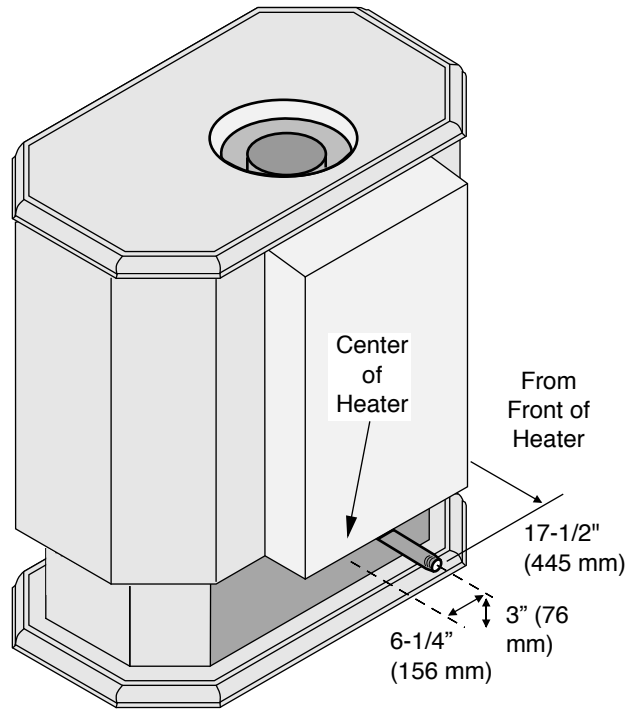

Gas Inlet Pressure

- With the heater off, the inlet pressure must meet the requirements listed in the table below
- ? If the pressure is not sufficient, make sure the piping used is large enough and the total gas load for the residence does not exceed the amount supplied.
- ? The supply regulator (the regulator that attaches directly to the residence inlet or to the propane tank) should supply gas at the suggested input pressure listed below. Contact the local gas supplier if the regulator is at an improper pressure.

	Standard Input Pressure
Natural Gas	7" W.C. (1.74 Kpa)
Propane	11" W.C. (2.73 Kpa)

Vent Requirements

- ! Always maintain the required 1" (25 mm) clearance (air space) to combustible materials to prevent a fire hazard. Do not fill air spaces with insulation.
- ! The gas appliance and vent system must be vented directly to the outside of the building, and never be attached to a chimney serving a separate solid fuel or gas-burning appliance. Each direct vent gas appliance must use it's own separate vent system.

- ! If the heater is installed at an altitude over 3,000 (1,000 M) feet the flame quality will need to be carefully evaluated. See Addendum #1, "Altitude Considerations", on page 33.

- When the vent passes through a wall, a wall thimble is required. When the vent passes through a ceiling, a support box or firestop is required. When the vent passes through the roof, a roof flashing and storm collar are required. Follow the instructions provided with the vent (from Duravent®) for installing these items.

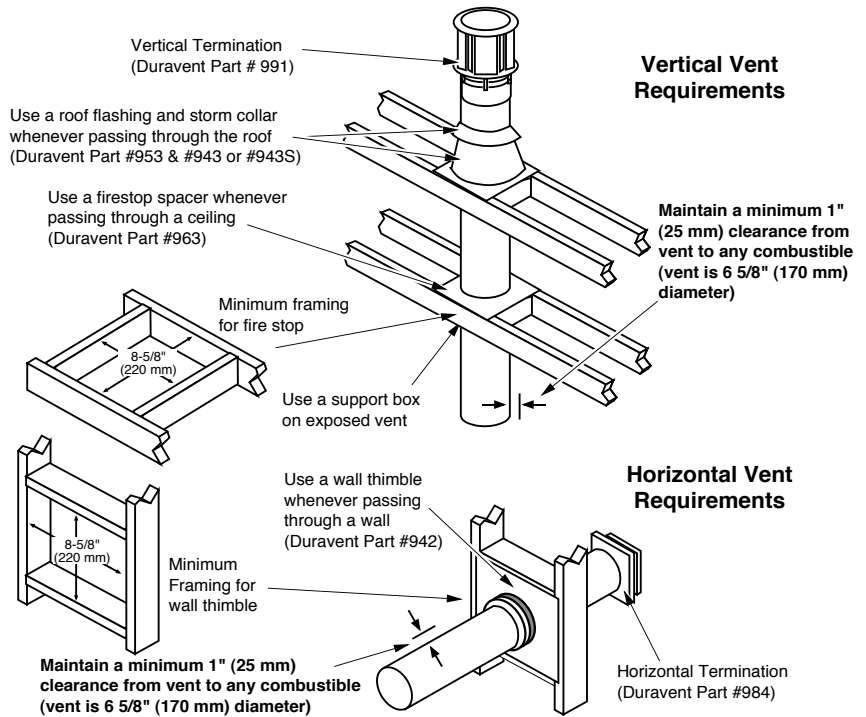

- Use Model GS Direct Vent manufactured by Simpson Dura-Vent **only** (or the Chimney Conversion Kit - see Addendum #2). Follow the installation instructions included with the vent. For the nearest Simpson Dura-Vent supplier, call (800) 835-4429. Part numbers and descriptions are listed below.

Straight Lengths	Vent Terminations	Penetration, Support Parts
908B 6" Pipe Length, Black (interior)	981 Snorkel Termination (36" rise) (for basement installations)	942 Wall Thimble
907B 9" Pipe Length, Black (interior)	982 Snorkel Termination (14" rise) (for basement installations)	940 Optional Wall Thimble Cover
906 12" Pipe Length, Galvanized	984 Horizontal Square Termination	941 Cathedral Ceiling Support Box
906B 12" Pipe Length, Black (interior)	950 Vinyl Siding Standoff	943 Flashing, 0/12 to 6/12 Roof Pitch
904 24" Pipe Length, Galvanized	991 Vertical Termination	943S Flashing, 7/12 to 12/12 Roof Pitch
904B 24" Pipe Length, Black (interior)		953 Storm Collar
903 36" Pipe Length, Galvanized	Elbows	963 Ceiling Firestop
903B 36" Pipe Length, Black (interior)	990 90° Elbow	988 Wall Strap
902 48" Pipe Length, Galvanized	990B 90° Elbow, Black (interior)	
902B 48" Pipe Length, Black (interior)	945 45° Elbow	
911B 11" to 14 5/8" Pipe, Adjustable, Black (interior)	945B 45° Elbow, Black (interior)	

- Apply high-temperature silicone to the male section of inner pipe (on the upper section of vent) so the silicone seals the inner pipe from the outer pipe when the sections are assembled. Slide the sections together and turn 1/4 turn until the sections lock in place. Install three metal screws through each joint to lock the outer section in place (see the instructions included with the vent for further details).

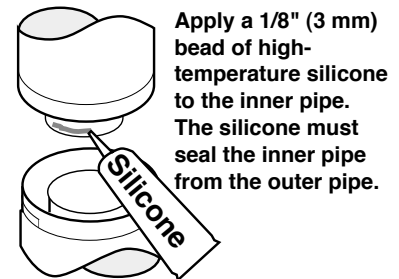

NOTE: You may screw the first section of vent to the appliance.

- Horizontal sections require a 1/4" (6 mm) rise every 12" (300 mm) of travel
- + Exterior Vent Diameter = 6-5/8" (170 mm), Inner Vent Diameter = 4" (100 mm)
- Horizontal sections require non-combustible support every 36" (910 mm) (e.g.: use plumbing tape)

Approved Vent Configurations

Restrictor Position

- A vent restrictor is built into the appliance to control the flow rate of exhaust gases. This ensures proper flames for the wide variety of vent configurations. The restrictor consists of a butterfly valve in the air inlet and an adjustment plate with index holes used to hold the valve in a fixed position. Depending upon the vent configuration, you may be required to adjust the restrictor position. The charts for approved vent configurations describe which position the vent restrictor must be in.

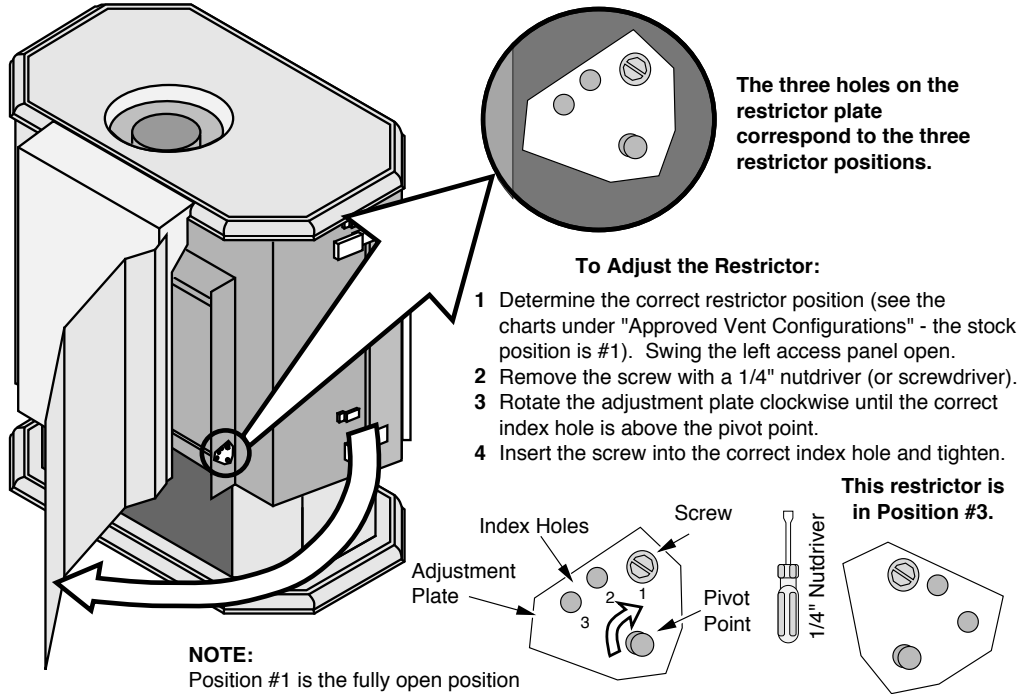

Elbows

- 2 Elbow maximum (two 45° or two 90°, not one 45° and one 90°)

Elbows add 3" (75 mm) to the length of the vent system.

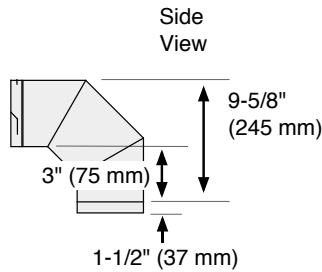

Vent Height is calculated to the top of the vent on horizontal terminations and to the top of the termination on vertical terminations.

Vent Horizontal Run (measure from the closest edge of the starter section to the end of the termination)

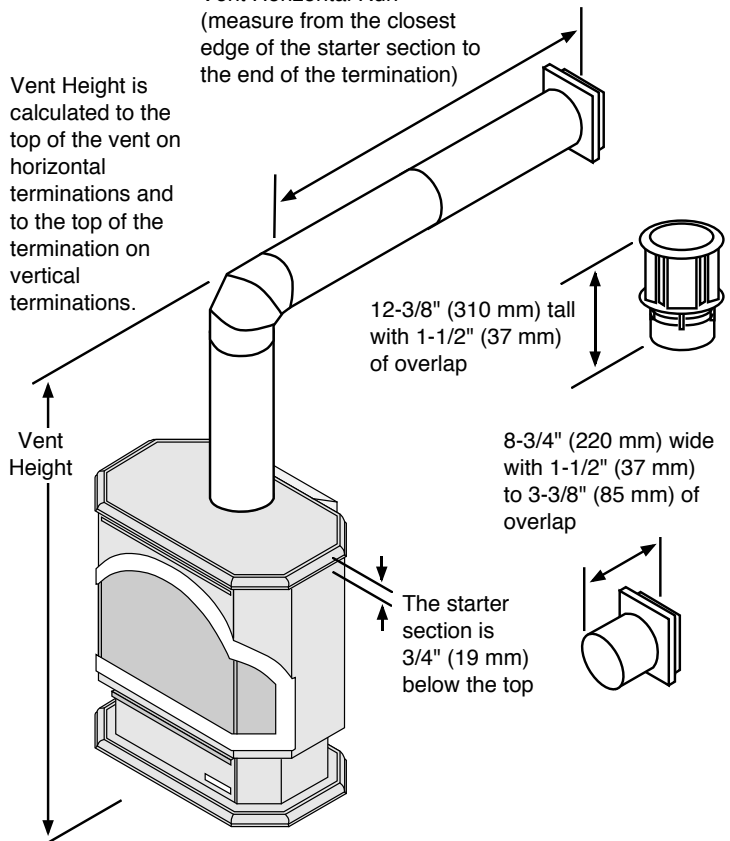

Measuring Vent Lengths

Vent sections overlap each other by 1-1/2" (37 mm)

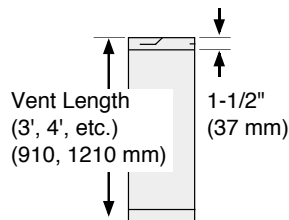

Approved Venting Configurations for Vertical Terminations with (or without) Two 45° Elbows

- 10' (3 M) Minimum System Height (with or without offsets)
- 35' (10.7 M) Maximum System Height
- 6' (1.8 M) Maximum Offset
- The termination must fall within the shaded area shown in the chart. Use the indicated restrictor position.
- If using offsets, use the table below to calculate the vertical rise and horizontal offset

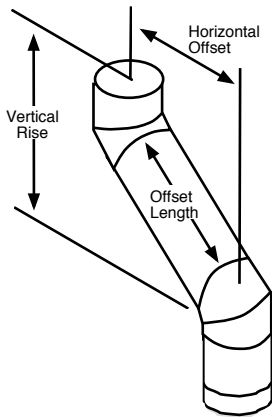

Offset Length	Hor. Offset	Vert. Rise
None	5" (125 mm)	1' (300 mm)
1' Section	1' (300 mm)	1' 7" (480 mm)
2' Section	1' 9" (530 mm)	2' 4" (710 mm)
3' Section	2' 5" (740 mm)	3' (915 mm)
4' Section	3' 2" (965 mm)	3' 8" (1.12 M)
4' + 1' Section	3' 9" (1.14 M)	4' 4" (1.32 M)
4' + 2' Section	4' 6" (1.37 M)	5' (1.52 M)
4' + 3' Section	5' 2" (1.57 M)	5' 9" (1.75 M)
4' + 4' Section	6' (1.83 M)	6' 9" (2.06 M)

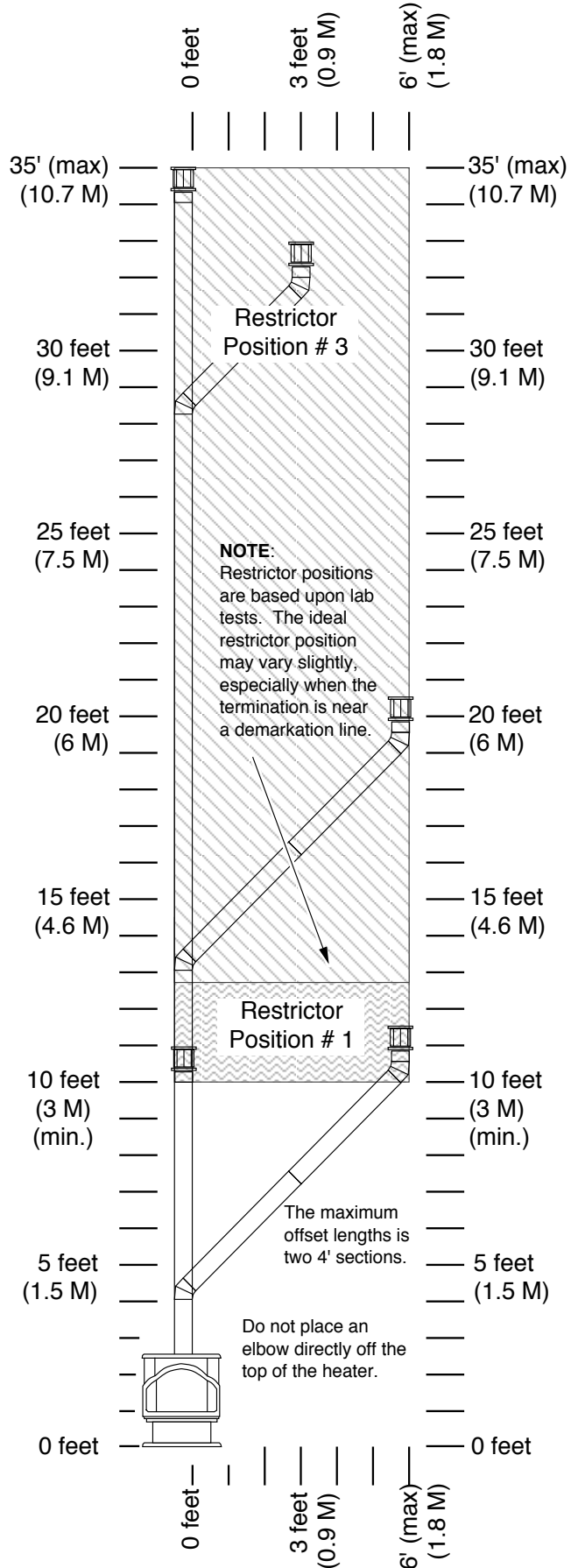

Approved Venting Configurations with a Horizontal Termination

- **Minimum 3' (.9 M) vertical section directly off the stove for propane, 2' (.5 M) for natural gas.**
- If using a **Snorkel Termination** (14" or 36") add the snorkel height to the vertical height (snorkel terminations are used primarily for basement installations).
- The termination must fall within the shaded area shown in the chart. Use the indicated restrictor position.

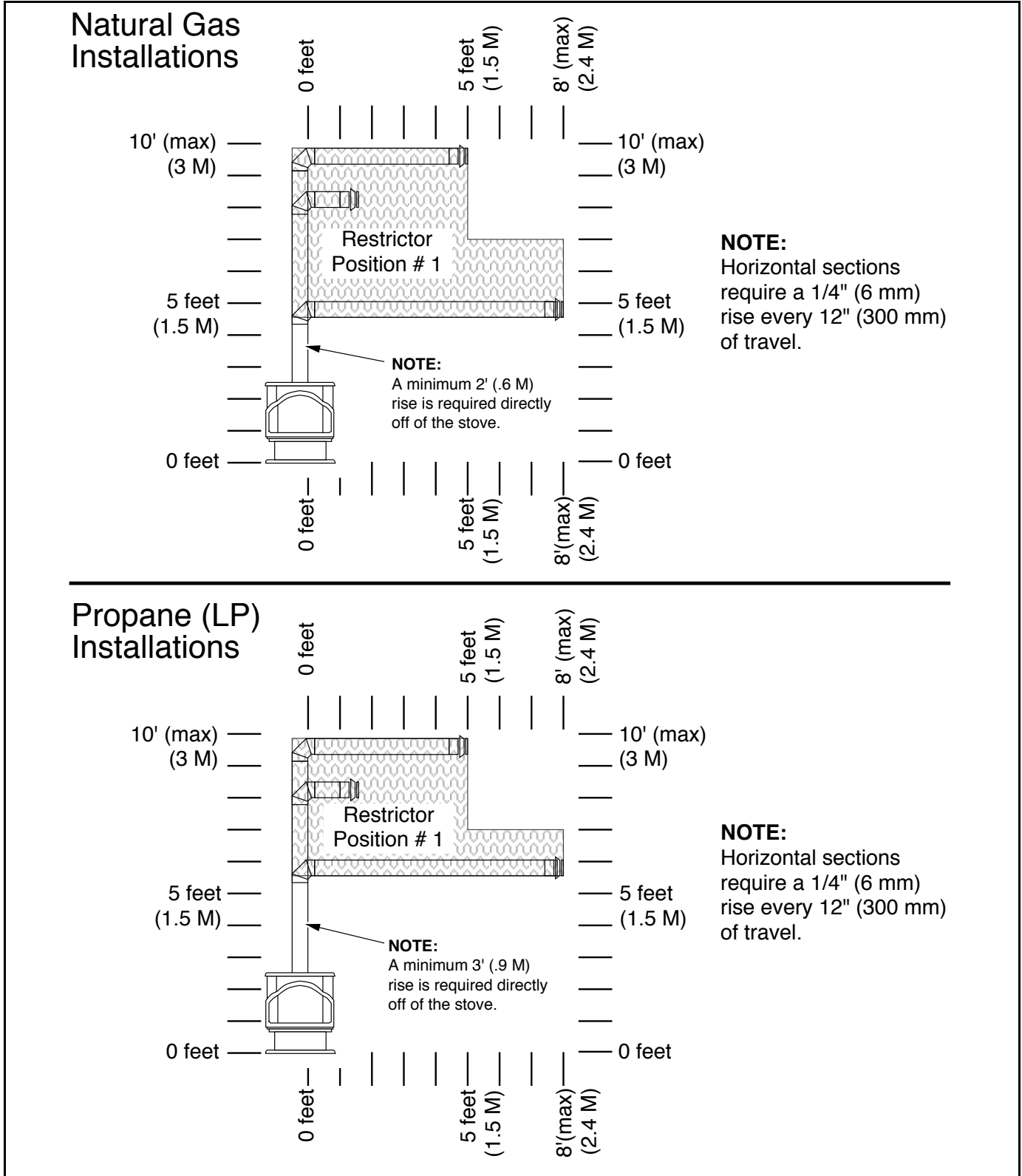

Approved Venting Configurations for Vertical Terminations with Two 90° Elbows

- The termination must fall within the shaded area shown in the chart. Use the indicated restrictor position.

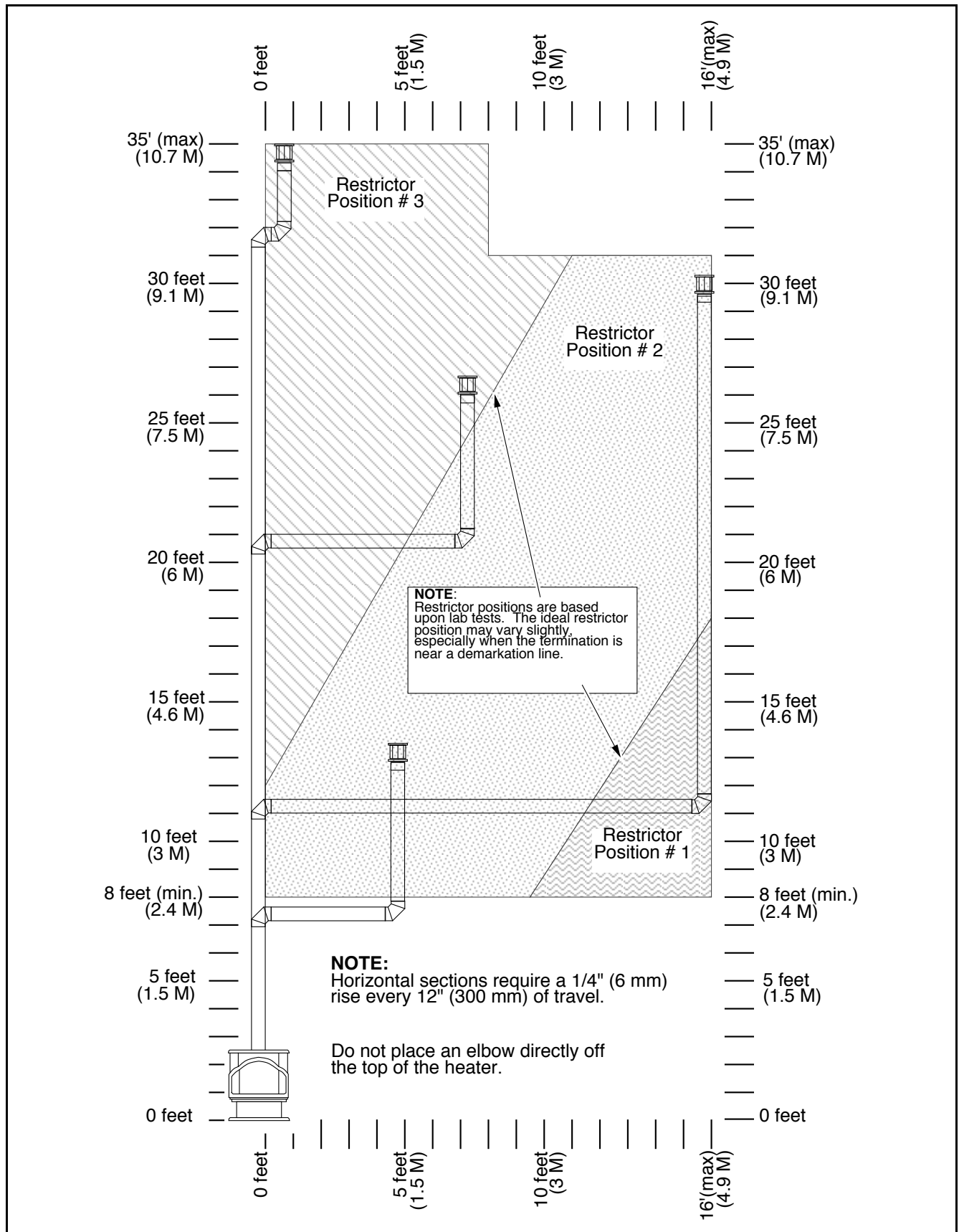

Horizontal Vent Termination Requirements (see the illustration below)

- A Minimum 9" (225 mm) clearance from any door or window
- B Minimum 12" (300 mm) above any grade, veranda, porch, deck or balcony
- C Minimum 12" (300 mm) from outside corner walls
- D Minimum 24" (600 mm) from inside corner walls
- E Minimum 11" (275 mm) clearance below unventilated soffits or roof surfaces
Minimum 18" (450 mm) clearance below ventilated soffits
Minimum 6" (150 mm) clearance from roof eaves
NOTE: Vinyl surfaces require 24" (600 mm)
- F Minimum 18" (450 mm) clearance below a veranda, porch, deck or balcony (must have two open sides)
- G Minimum 48" (1220 mm) clearance from any adjacent building
- H Minimum 84" (2130 mm) clearance above any grade when adjacent to public walkways or driveways
NOTE: may not be used over a walkway or driveway shared by an adjacent building
- I Minimum 48" (1220 mm) clearance from any mechanical air supply inlet, 72" (1820 mm) for Canada
- J Minimum 36" (910 mm) clearance above and 48" (1220 mm) below and to the sides of non-mechanical air supply inlet
- K Minimum 36" (910 mm) from the area above the meter/regulator (vent outlet)
- L Minimum 36" (910 mm) from the meter/regulator (vent outlet)

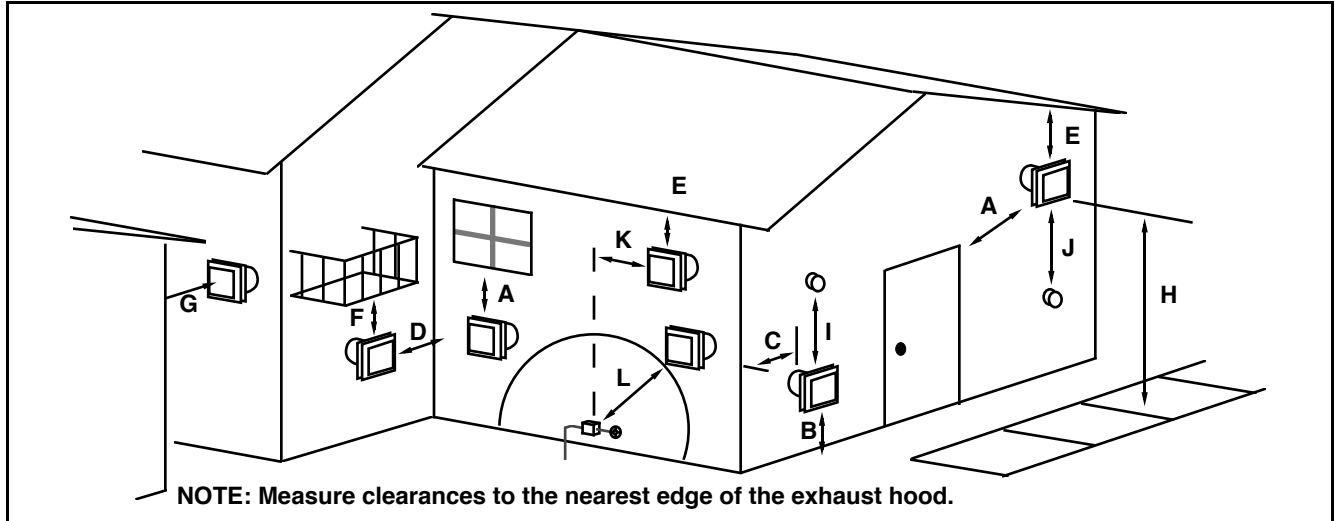
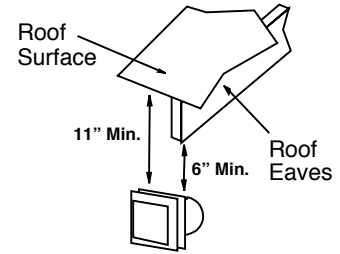

- Use the vinyl siding standoff (#950) when installing on an exterior with vinyl siding.
- Vent termination must not be located where it will become plugged by snow or other material
- These clearances meet UMC-1994 and the CNA/CGA-B149 code standards

Vertical Vent Termination Requirements (see the illustration below)

Roof Pitch	Minimum Height*
Flat to 6/12	1' (.3 M)*
6/12 to 8/12	1.5' (.45 M)*
8/12 to 9/12	2' (.6 M)
9/12 to 10/12	2.5' (.75 M)
10/12 to 11/12	3.25' (1 M)
11/12 to 12/12	4' (1.2 M)
12/12 to 14/12	5' (1.5 M)
14/12 to 16/12	6' (1.8 M)
16/12 to 18/12	7' (2.15 M)
18/12 to 20/12	7.5' (2.25 M)
20/12 or greater	8' (2.45 M)

* In Canada the vent termination must be a minimum 2' (.6 M) tall and 2' (.6 M) above any portion of the roof within 10' (3 M) of the vent.

Electrical Connection

- Plug the power cord into a grounded 120 Volt outlet (do not remove the grounding plug).

! Turn the gas control valve to "OFF" prior to conducting any service.

1 Follow the directions below to install the burner pan.

a Remove the control panel.

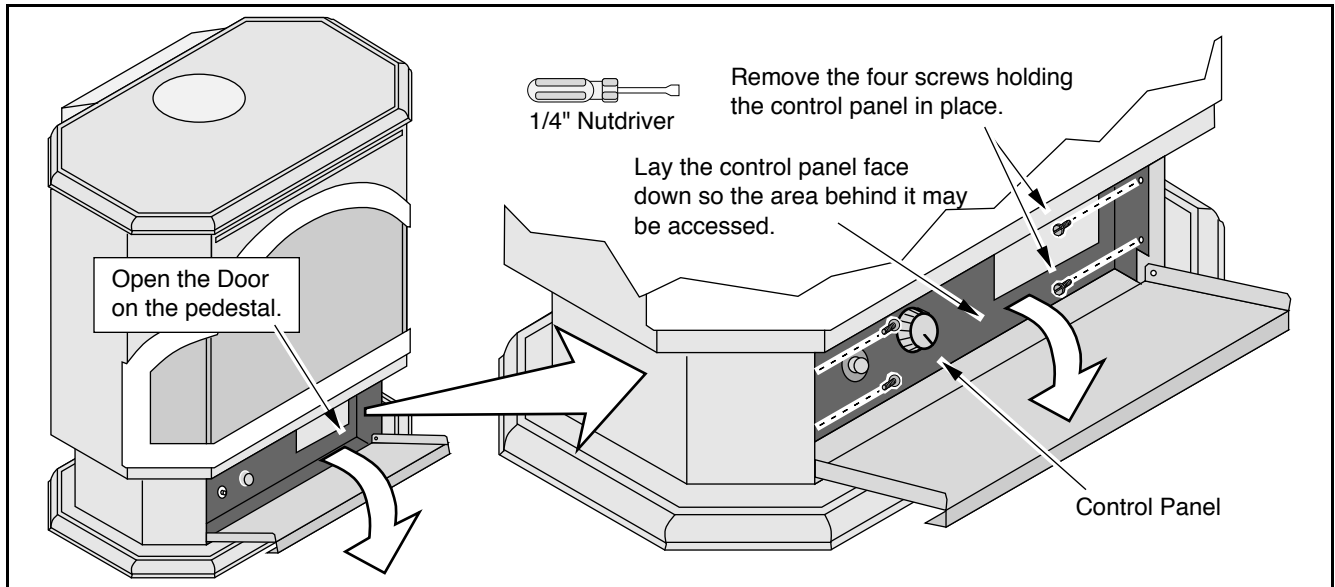

b Remove the burner pan from the packaging, place it upside down, and remove the boxing brackets (they may be discarded).

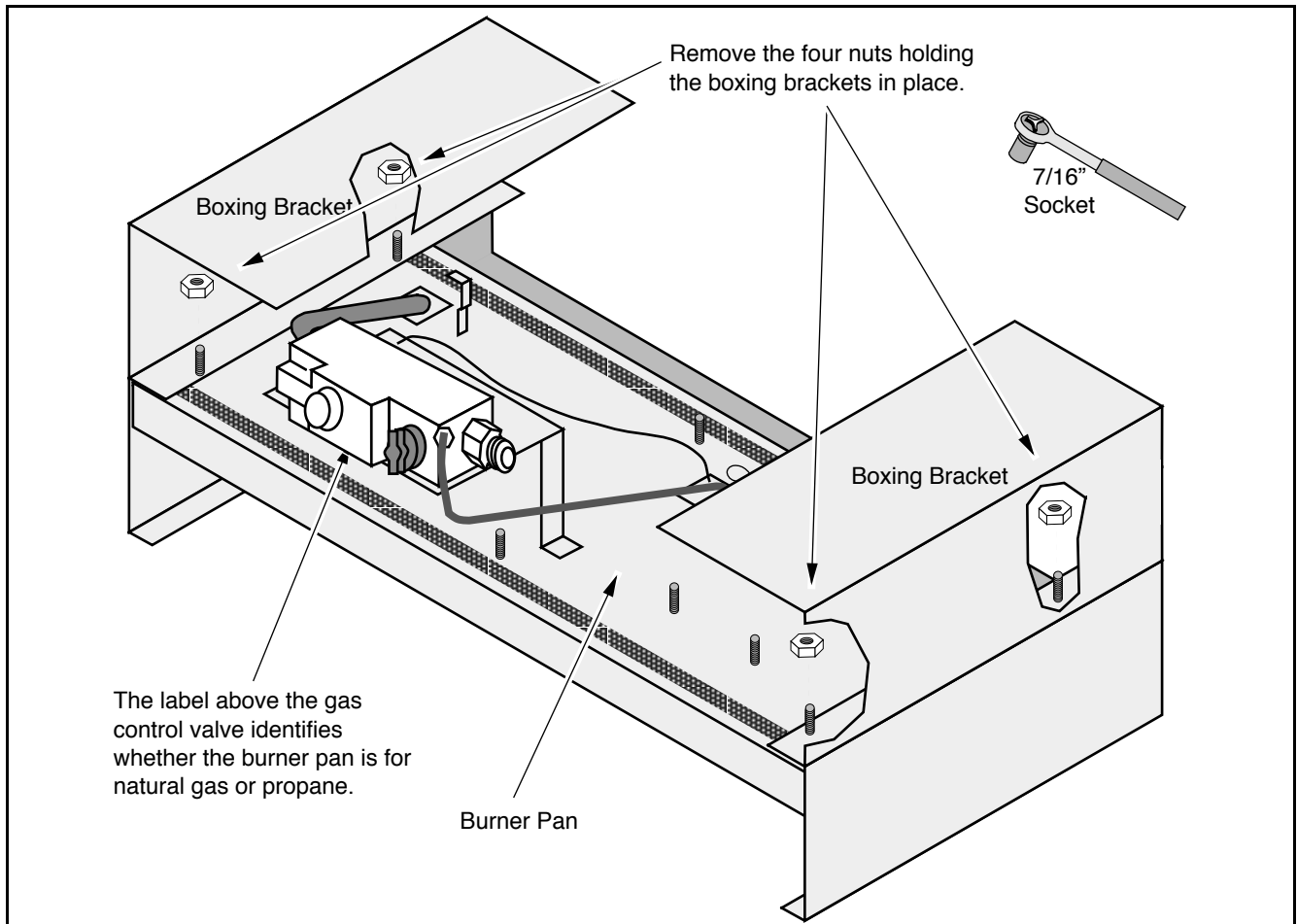

c Open the door following the directions below.

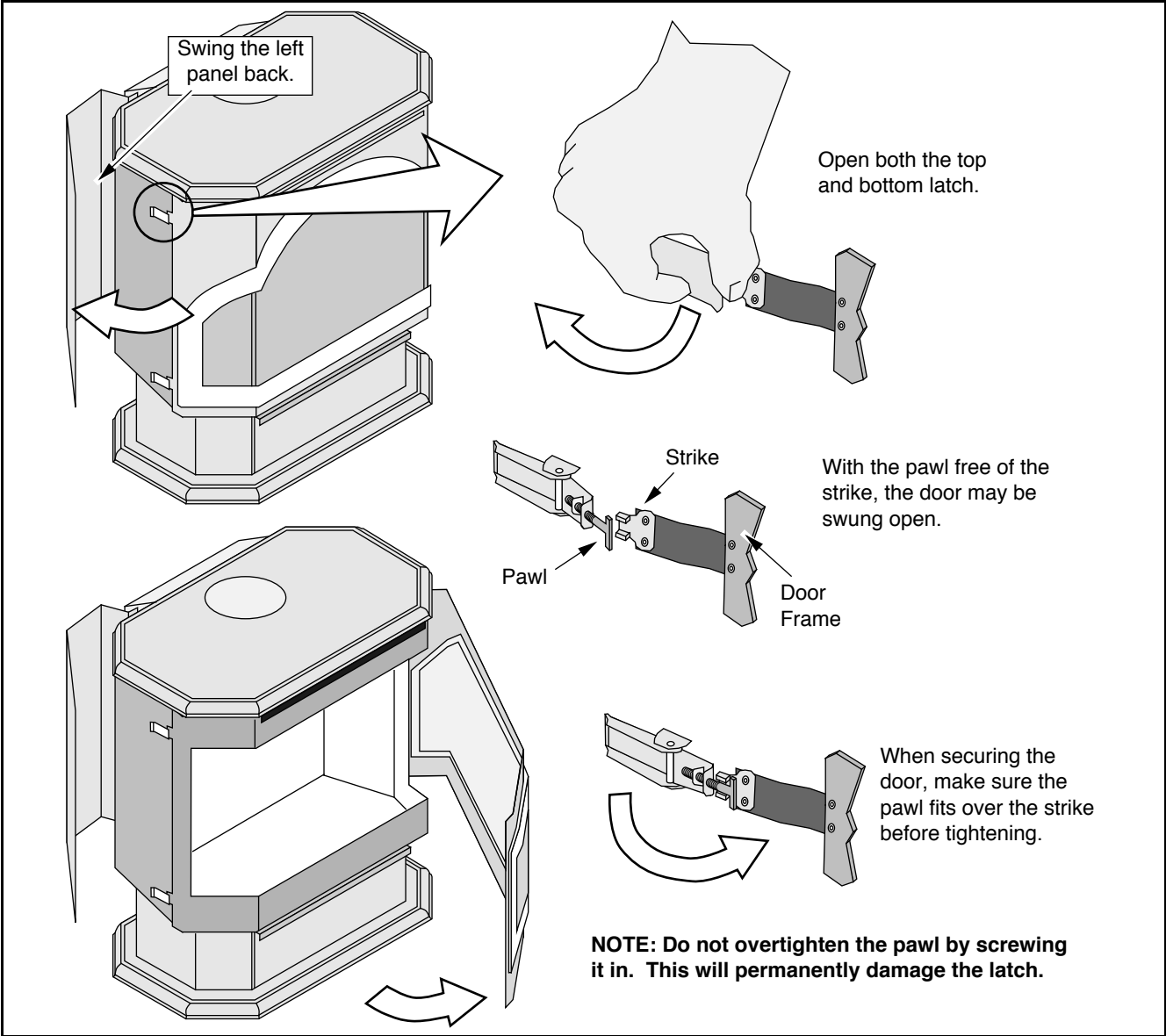

d Follow the directions below to install the burner pan and attach the piezo igniter wire.

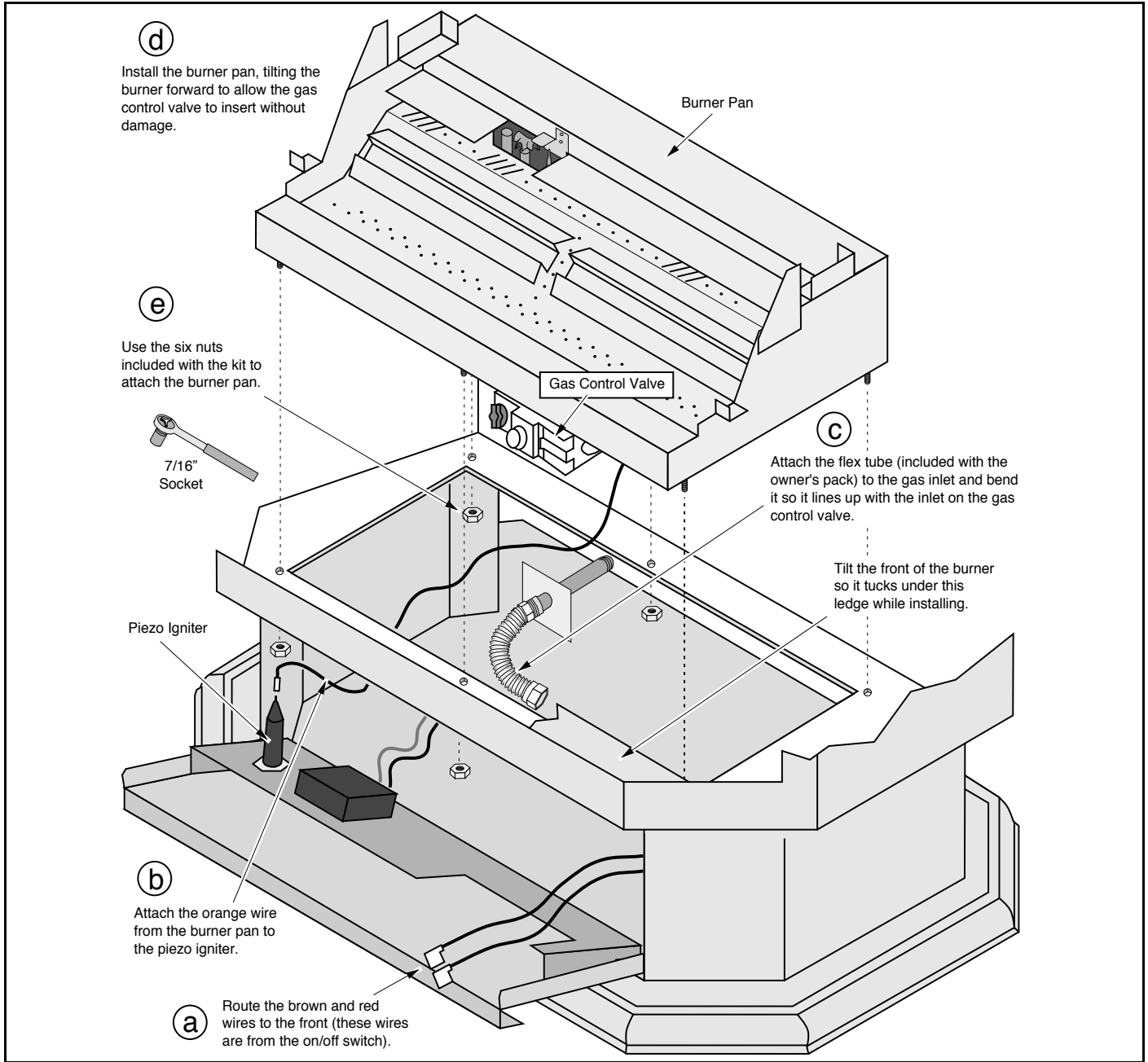

e Attach the brown and red wires from the on/off switch to the gas control valve.

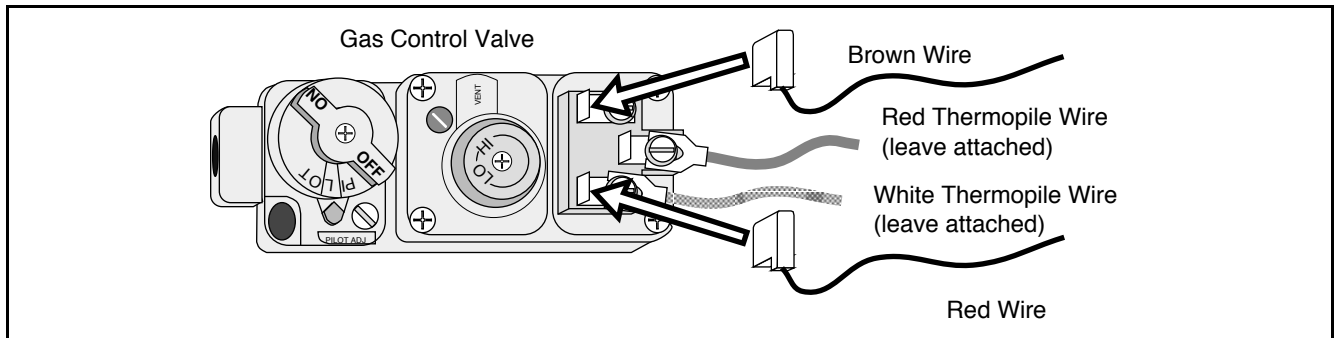

f Replace the control cover removed in step 1.

- 2 Connect the gas line. Use a 3/4" wrench to keep the fitting on the gas valve from rotating while using a 7/8" wrench to screw in the flex tube connection.
- 3 Install the log set and coals.

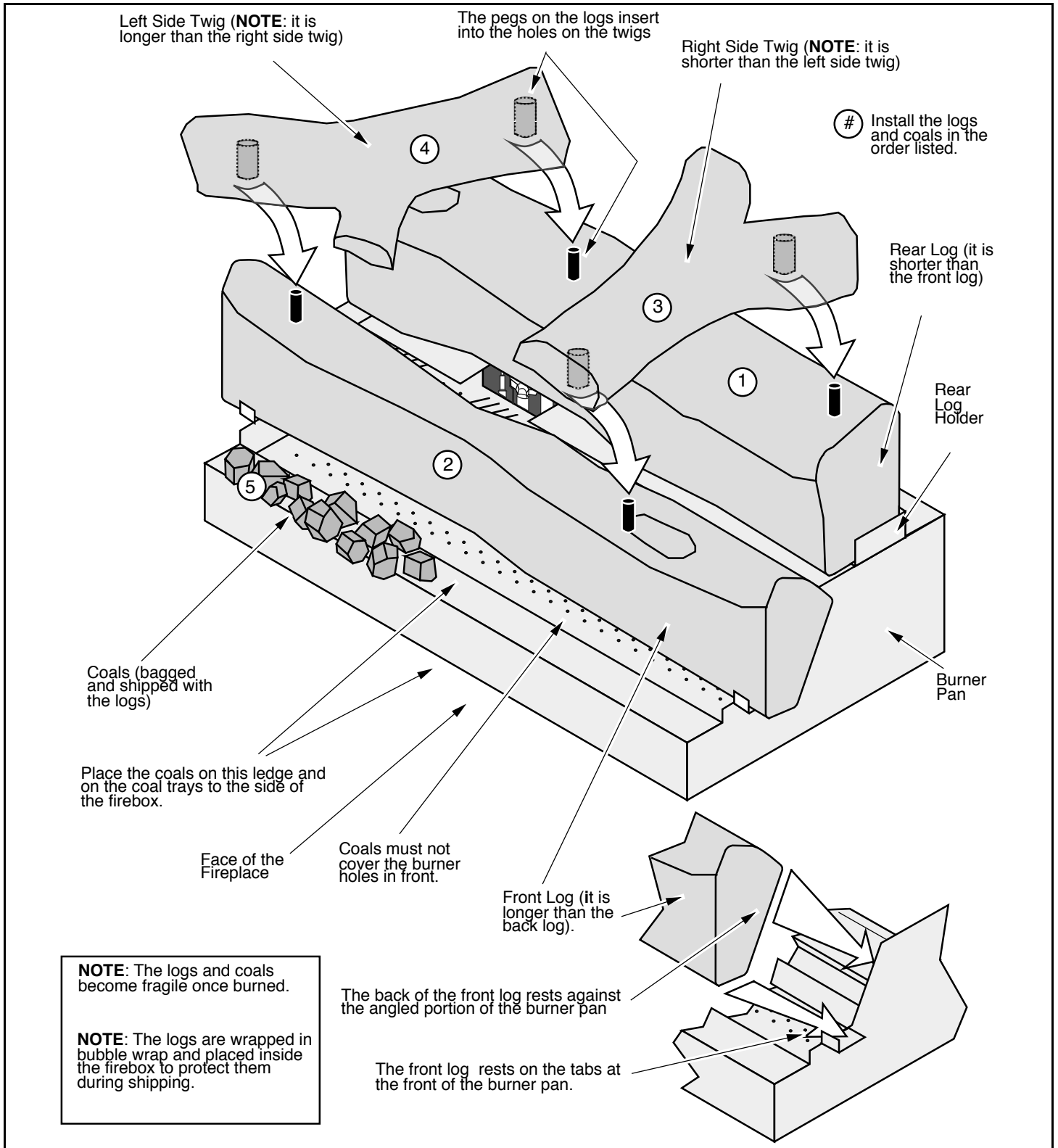

! We recommend you purge the gas line at this time (with the door open). This allows gas to be detected once it enters the firebox, ensuring gas does not build up.

4 Close and secure the door (see step 1c).

5 Turn on gas to the heater. Leak test all gas joints prior to starting the appliance. Start the pilot. Start the main burner. Leak test all gas joints again.

7 Check the pilot flame to make sure it looks like the illustration to the right. Adjust the pilot flame if necessary.

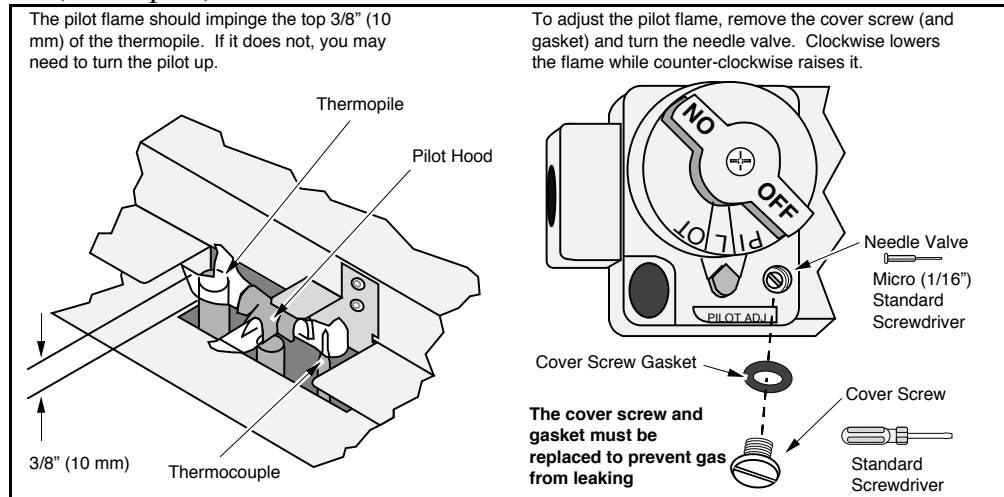

6 Let the heater burn for fifteen minutes. Adjust the air shutter, if necessary, to achieve the correct looking flame (see the illustration to the right).

The air shutter adjusts the amount of air that mixes with the gas before it exits the burner holes. It is used to fine-tune the flame for differences in altitude and vent configuration.

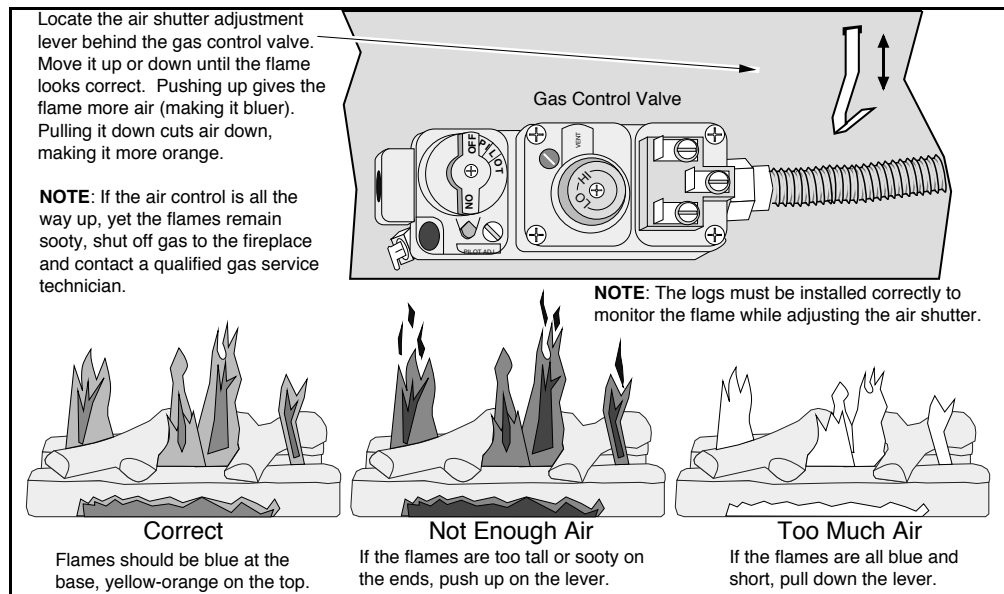

! If the air shutter is in its fully open position, yet the flames remain sooty, shut off gas to the heater and contact your dealer for a remedy.

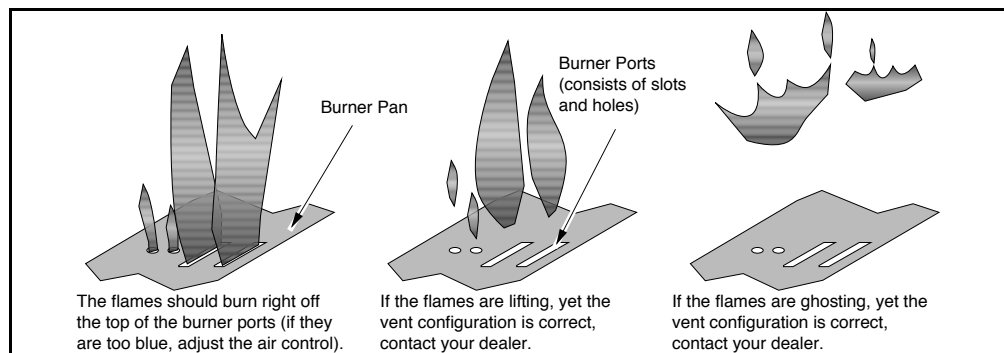

! If the vent configuration is installed incorrectly the vent may cause the flames inside the heater to lift or "ghost" – a dangerous situation. Inspect the flames after installation to insure proper performance. If the vent configuration is correct, yet the flames are lifting or ghosting, shut off gas to the heater and contact the dealer for information on remedying the problem.

7 Turn the flame adjust knob to its highest position - the flames should be approximately 12" tall. Check the flame on low position. The flames should burn off of each burner hole. If the heater does not work correctly, contact your dealer for a remedy.

8 Give this manual to the home owner and fully explain the operation of this heater.

Before You Begin

! Read this entire manual before you use your new heater (especially the section "Safety Precautions" on pages 2 & 3). Failure to follow the instructions may result in property damage, bodily injury, or even death.

Location of Controls - See explanation below

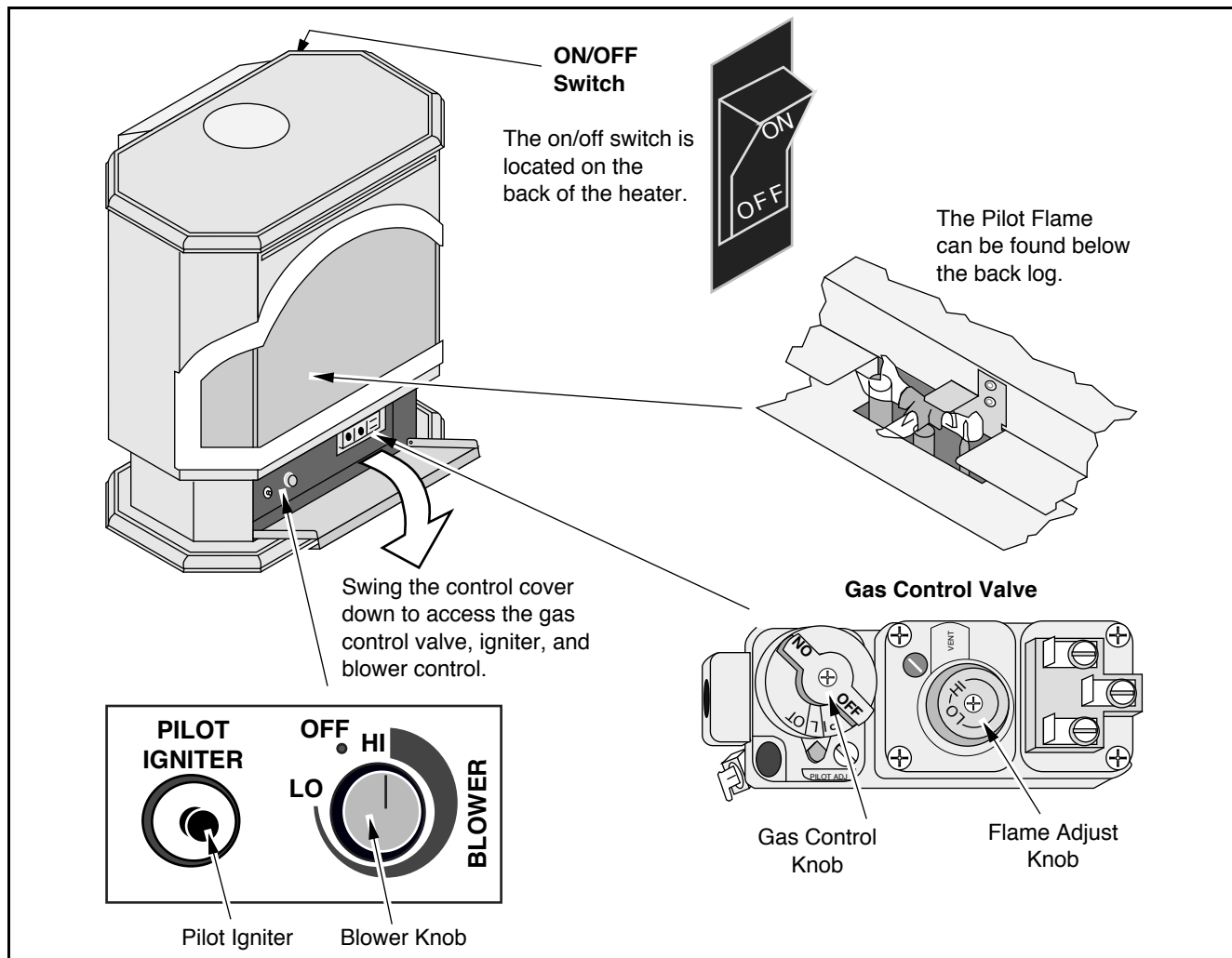

On/Off Switch

This control is used to turn the main burner on and off.

Gas Control Knob

This knob is used to control gas to the heater and for starting the pilot. There are three positions, ON, OFF, & PILOT. The pointer directly below the knob indicates the position this knob is in.

Flame Adjust Knob

This knob controls the flame height from low ("LO") to high ("HI"). The pointer to the upper left of the knob points to the position this knob is in.

Pilot Igniter

The pilot igniter is used only to start the pilot. When pressed, it sends an electrical charge to the pilot assembly. This creates a blue spark directly next to the pilot, igniting the pilot flame.

Blower Knob

This knob controls the speed of the internal convection blower that pushes the heated air into the room.

? If using a remote control or thermostat, the On/Off Switch must be left "ON". Turning the On/Off Switch "OFF" will keep the heater off always.

Starting The Pilot Flame

The pilot flame is required to ignite the main burners (it also plays a safety role). It should be left on once lit. It will stay lit unless the gas control valve is turned to "OFF". However, the pilot will go out if the gas is shut off or if the stove malfunctions. If the pilot turns off frequently, call your dealer for information. To start the pilot follow the directions below:

NOTE: IF YOU'RE TRYING TO RE-LIGHT THE PILOT BECAUSE SERVICE WAS PERFORMED ON THE UNIT (I.E. GAS LINE REMOVED THEN RE-INSTALLED OR BECAUSE TANK RAN OUT OF GAS), FOLLOW THE INSTRUCTIONS FOR REMOVING THE GLASS AND LOGS ON PAGES 26 THROUGH 28 THEN BLEED THE GAS LINE.

A Push the gas control knob in slightly and turn it to the "OFF" position. The knob will not turn from "ON" to "OFF" unless the knob is depressed slightly.

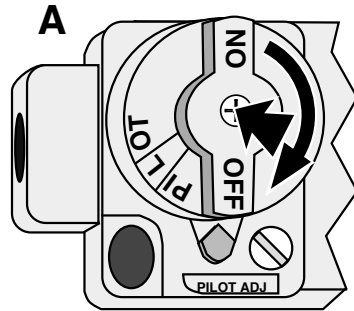

B Wait five minutes to let any gas that may have accumulated inside the firebox escape. If you smell gas, follow the directions on the cover "IF YOU SMELL GAS".

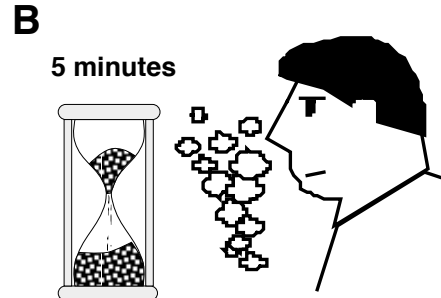

C Turn the gas control knob to the "PILOT" position and press the knob in, this will allow gas to flow to the pilot light. Press the red button on the pilot igniter repeatedly until you see the pilot light. **KEEP THE GAS CONTROL KNOB DEPRESSED FOR 30 SECONDS ONCE IT IS LIT. NOTE: IF THE PILOT DOES NOT LIGHT AFTER 15 SECONDS, RELEASE THE KNOB AND CALL YOUR DEALER FOR SERVICE.**

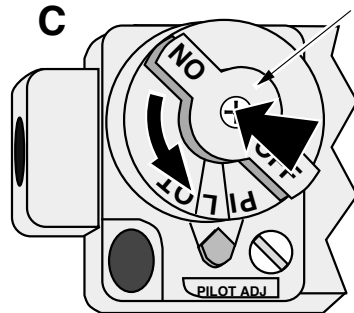

Do not press knob in for more than 15 seconds if pilot does not light. Call Your Dealer For Service

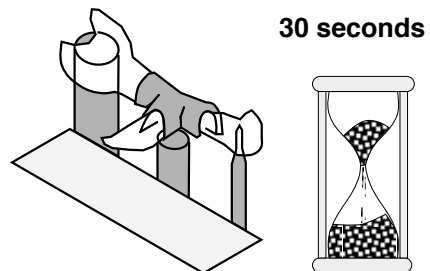
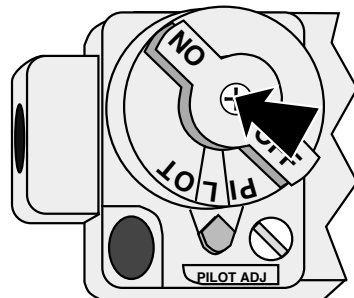
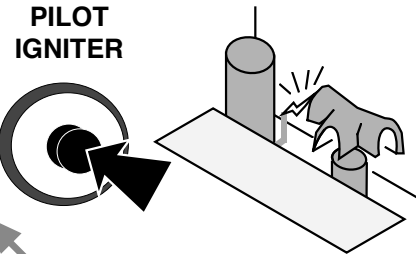

D Release the gas control knob. If the pilot goes out, repeat step C. If the pilot refuses to stay lit, call your dealer for service.

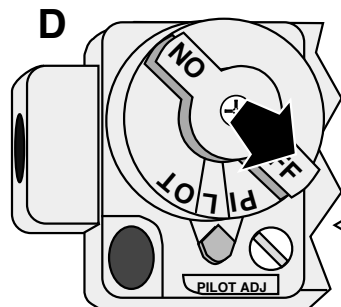

E Turn the gas control knob counter-clockwise to "ON". The pilot is now lit and the stove can be turned on and off.

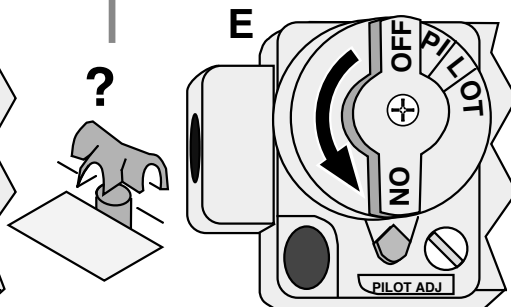

Starting the Heater for the First Time

- + **Fumes** and smoke from the paint curing and oil burning off the steel may occur the first time you start your heater. This is normal. We recommend you open windows to vent the room.
- + **Condensation** may appear on the glass each time you start the heater - this is normal.
- + **Blue Flames** will occur on the heater when it first comes on. After fifteen minutes the flames will turn a more realistic yellow and orange color.
- ? Certain installations use a remote "wall switch" to turn the heater on and off. If this is the case, leave the ON/OFF switch "ON".

Turning the Heater On and Off

After the pilot has been started...



Use this switch to turn the main burner on and off manually.

For systems with thermostat remotes, make sure the On/Off Switch shown to the left is on. Refer to the instructions included with the remote for full details.

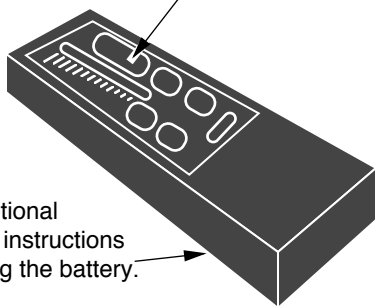

See the optional equipment instructions for installing the battery.

For systems with thermostats, use this switch to control the temperature (right is hotter, left cooler). Some systems require the on/off switch to be on.

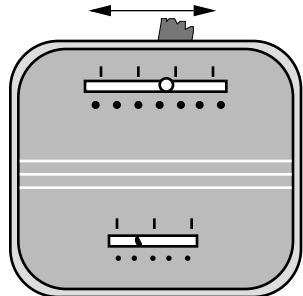

- ! Do not place any combustible items on top of or directly in front of the heater, even temporarily. The optional thermostat may start the heater causing a combustible item to ignite.
- ? If the heater turns on and off frequently while using the thermostat, you may want to adjust the flame height down until it produces just enough heat needed.

Adjusting the Flame Height

- + Your heater has an adjustable flame to tailor the look and heat output to your specific needs. It is adjusted by turning the middle dial on the gas control valve.

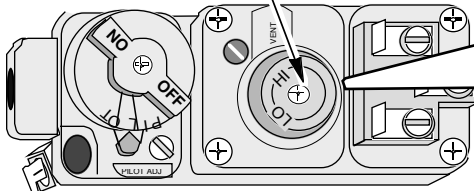

Flame Height Adjustment Knob

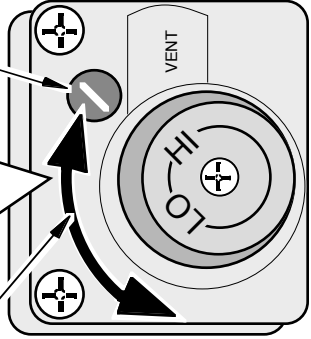

Index Mark

Turn clockwise to adjust the flame higher, counter-clockwise to lower.

Adjusting the Blower Speed

- + The blower helps transfer the heat from the heater into the room. It will not turn on until the heater is up to temperature (approximately 10 minutes after starting). See the illustration below for instructions on adjusting the blower speed.

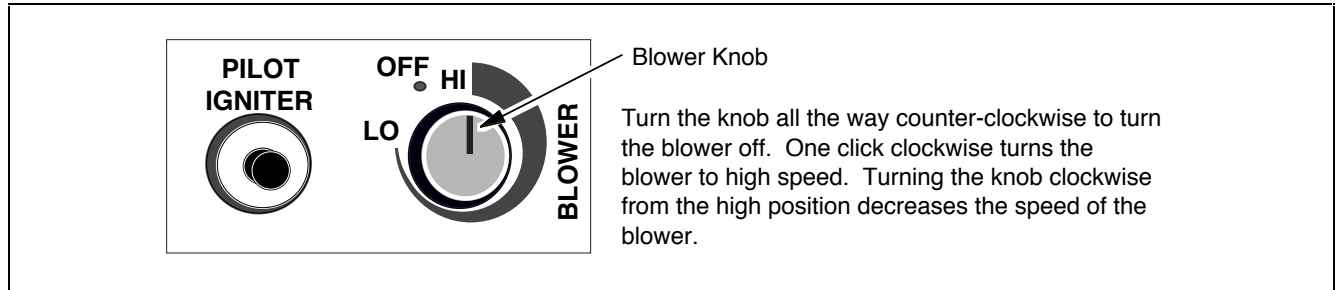

Normal Operating Sounds

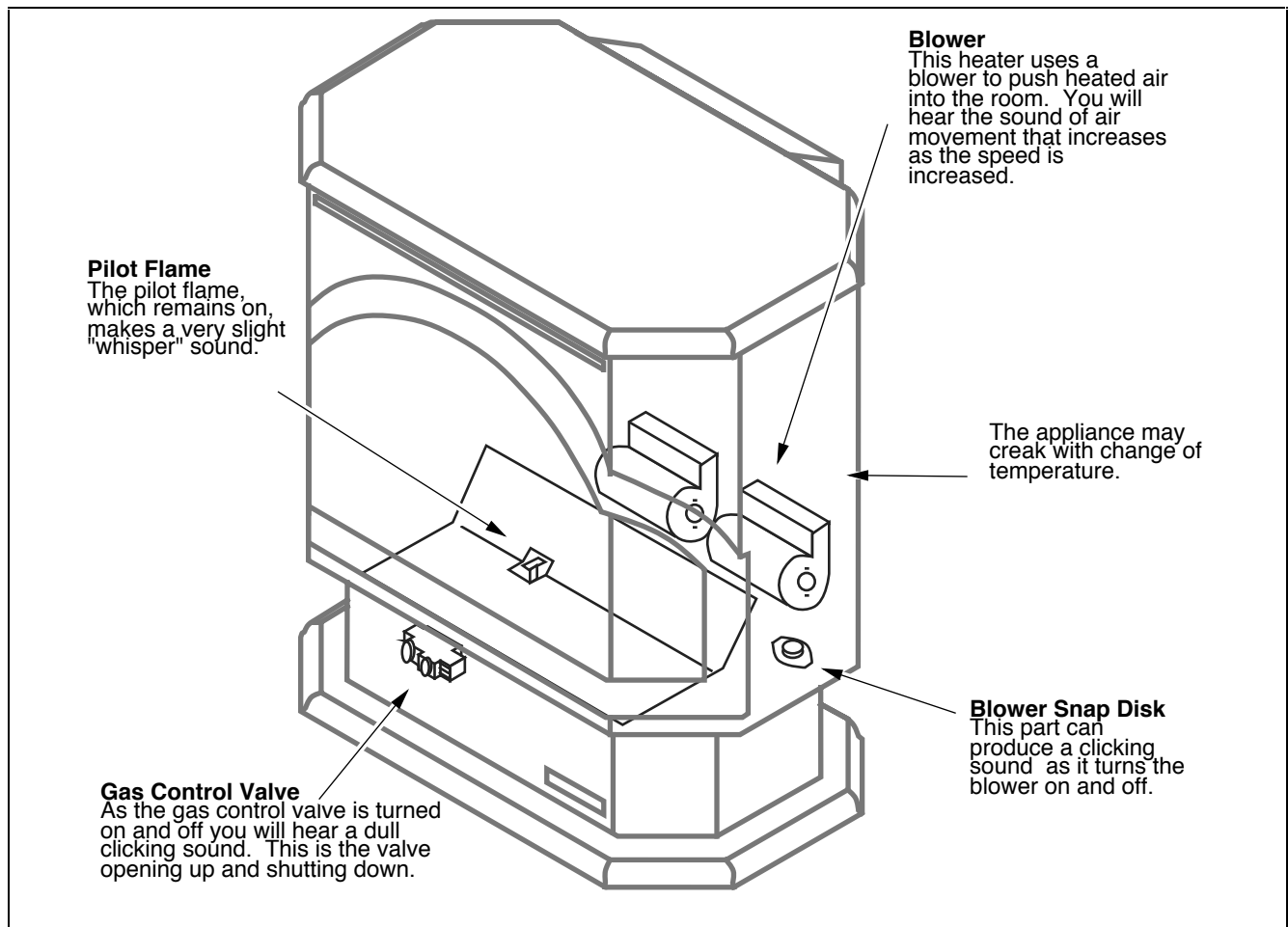

Cleaning Your Heater

- ! Fingerprints or other marks left on the optional gold surface may become etched in place if they are not wiped clean prior to turning the stove on. Clean the gold with denatured alcohol and a soft cloth.
- With the heater cool, use denatured alcohol and a soft cloth to clean gold surfaces. Other cleaners may leave a film that may become etched into the gold.

Yearly Service Procedure

- ! Failure to inspect and maintain the heater may lead to improper combustion and a potentially dangerous situation. We recommend the following procedures be done by a qualified technician.
 - 1 Check the pilot flame. It should engulf approximately 3/8" of the top of the thermocouple (see illustration below). If it does not, contact your dealer for service.
 - 2 Shut off gas to the heater by turning the gas control knob to "OFF" (see step A under "Starting the Pilot" on page 20). Let the heater cool for 15 minutes. Open the door (see step c on page 15).
 - 3 Remove the logs, twigs and embers (see page 17 - **NOTE: the logs are fragile**). If any log is cracked or deteriorated, replace it when re-installing. Check the logs for sooting. A small amount of soot along the bottom of the logs is normal. If excessive sooting is found, the heater will require adjustment. Contact your dealer.
 - 4 Clean the burner pan (especially in the burner holes and slots) and inspect the following:
 - Check for burner pan holes that are cracked, severely warped, or corroded.
 - Make sure the burner pan assembly fits flat against the floor of the firebox.
 - Check the firebox and area around the pilot to make sure there is no warping or damage.
- If any problem is found, discontinue use and contact your dealer for service.

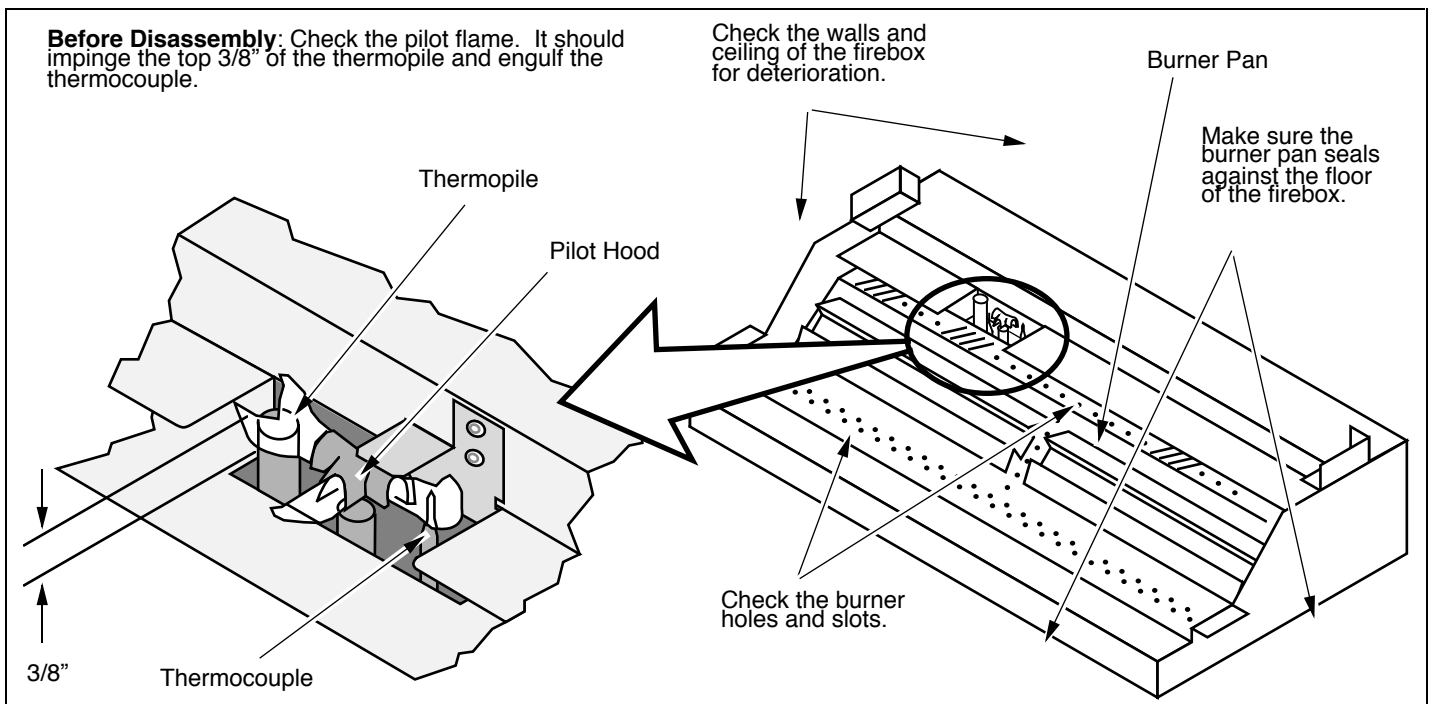

- 5 Replace the log set. Inspect the glass gasket. If it is deteriorated, replace. It may be re-attached to the glass using high-temperature gasket cement. If the glass is damaged, replace it.
- 6 Check the gas control valve and all of the gas lines. If any damage is found, discontinue use and contact your dealer for service.

- 7 To check the door seal, place a dollar bill along the door perimeter then close and latch the door. If the dollar bill is held in place securely, the door seal is adequate. However, if the dollar bill slides out easily, you should adjust the door. See the directions below to tighten the door seal.

To tighten the door seal:

- Open the door (see page 15).
- Tighten each door latch pawl one turn.
- Close and latch the door. Open up the right side panel. Loosen the two attachment nuts on each hinge assembly 1/2 turn. Adjust both adjustment nuts on each hinge assembly 1 turn to bring the hinge closer to the rear of the heater (Note: the dimple above the hinge assembly can be used to gauge hinge location). Re-tighten the attachment nuts.
- Check the door seal again. If it is still not tight, repeat the above three steps.

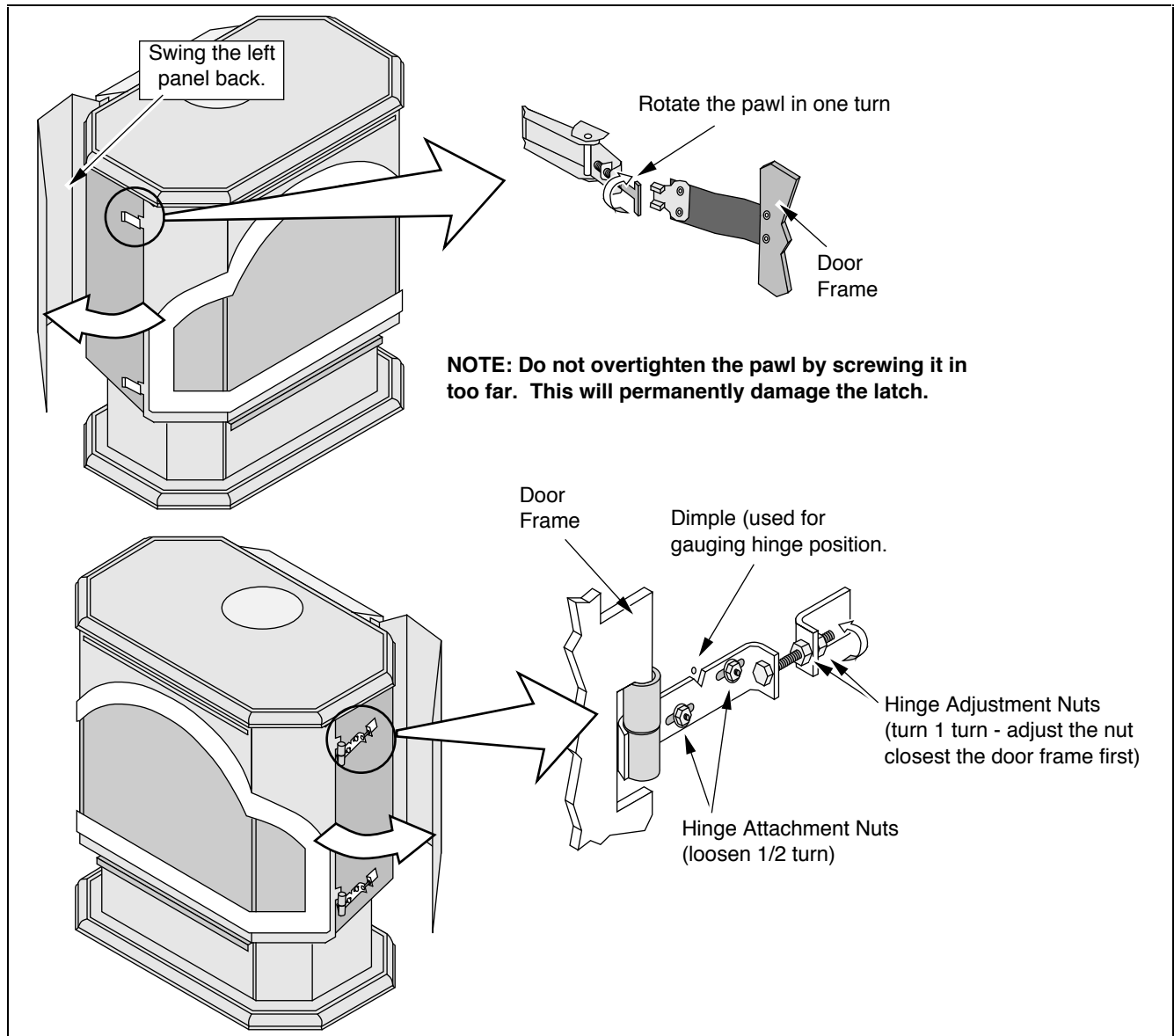

- 8 Start the pilot and turn on the main burner. The flames should be orange/yellow and not touch the top of the firebox. If the pilot or main burners do not burn correctly, contact your dealer for service. Monitor the blower operation.
- 9 Remove any debris or vegetation near the vent termination. Contact your dealer if any sooting or deterioration is found near the vent termination.

Problem:	Possible Cause:	Don't Call for Service Until You:
Pilot Will Not Flame	A gas shut off valve is turned off.....	Check all gas shut off valves
	The gas control knob isn't turned to "PILOT".....	See "Starting the Pilot Flame" Pg 20
	The valve control knob isn't pushed in.....	See "Starting the Pilot Flame" Pg 20
	The igniter wasn't pressed repeatedly.....	See "Starting the Pilot Flame" Pg 20
Main Burners Will Not Start	The pilot flame has gone out.....	See "Starting the Pilot Flame" Pg 20
	The gas control valve is turned to "PILOT" or "OFF".....	See "Starting the Pilot Flame" Pg 20
	The ON/OFF switch is turned to "OFF".....	Turn the ON/OFF switch to "ON"
	The remote control is not working correctly.....	Replace the batteries
	The thermostat is disconnected or set too high.....	Set the thermostat to a lower temperature
Remote Control Does Not Work	The pilot light has gone out.....	See "Starting the Pilot Flame" Pg 20
	The gas control valve is turned to "PILOT" or "OFF".....	See "Starting the Pilot Flame" Pg 20
	The ON/OFF switch is turned to "OFF".....	Turn the ON/OFF switch to "ON"
	The remote is too far away from the heater.....	Use the remote closer to the heater
	The remote control receiver is turned "OFF".....	Switch receiver to "ON" or "REMOTE"
	One of the two remote control batteries is dead.....	See "Remote Control Operation"
Thermostat Does Not Work	The pilot flame has gone out.....	See "Starting the Pilot Flame" Pg 20
	The gas control valve is turned to "PILOT" or "OFF".....	See "Starting the Pilot Flame" Pg 20
	The ON/OFF switch is turned to "OFF".....	Turn the ON/OFF switch to "ON"
	The thermostat is set too high.....	Set the thermostat to a lower temperature
Blower Does Not Operate	The heater is not getting electricity.....	Check the outlet switch
	The heater is not up to temperature.....	See "Operating Your Heater"
Flames Are Too Blue	The heater has just been started.....	This is normal - see "Starting the Heater for the First Time"
Flames Are Too Short (Under 6")	The flame height may be turned too low.....	Turn the flame height to "HI" - See "Adjusting the Flame Height"

How this Heater Works

- ! This heater was designed with safety as the primary concern. Many of the components inside this heater are for safety purposes. Therefore, only certified gas service technicians should service this heater.

What Turns the Main Burners On and Off

This heater uses a millivolt system to control its operation (a millivolt is a very small amount of electricity). The thermopile and thermocouple generate electricity when heated by the pilot flame. This electricity is used to operate the gas valve. Without enough electricity, the gas valve will not turn on. That is why when starting the pilot the gas control knob has to be pressed in long enough for the thermocouple to heat up and generate enough electricity. The thermopile provides power for the ON/OFF switch, remote control, or thermostat (see the illustration below). Because the thermopile generates the electricity needed to turn the heater on and off, this heater can be operated when the power is out (although the blower will not run).

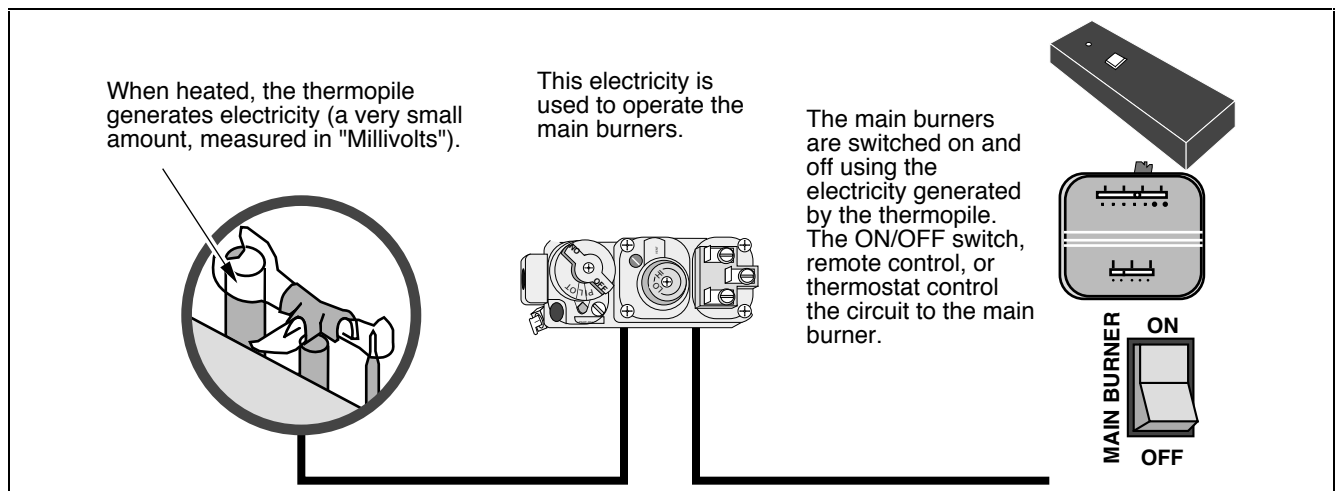

What Prevents Gas Buildup

- + This appliance utilizes a high-technology gas valve in conjunction with a pilot flame to ensure no gas builds up inside the firebox.
- + The thermocouple (next to the pilot) senses when the pilot flame is lit. If the pilot flame goes out, this thermocouple no longer generates electricity, causing the gas valve to automatically shut off all gas to the heater, preventing the pilot from spilling gas into the firebox.

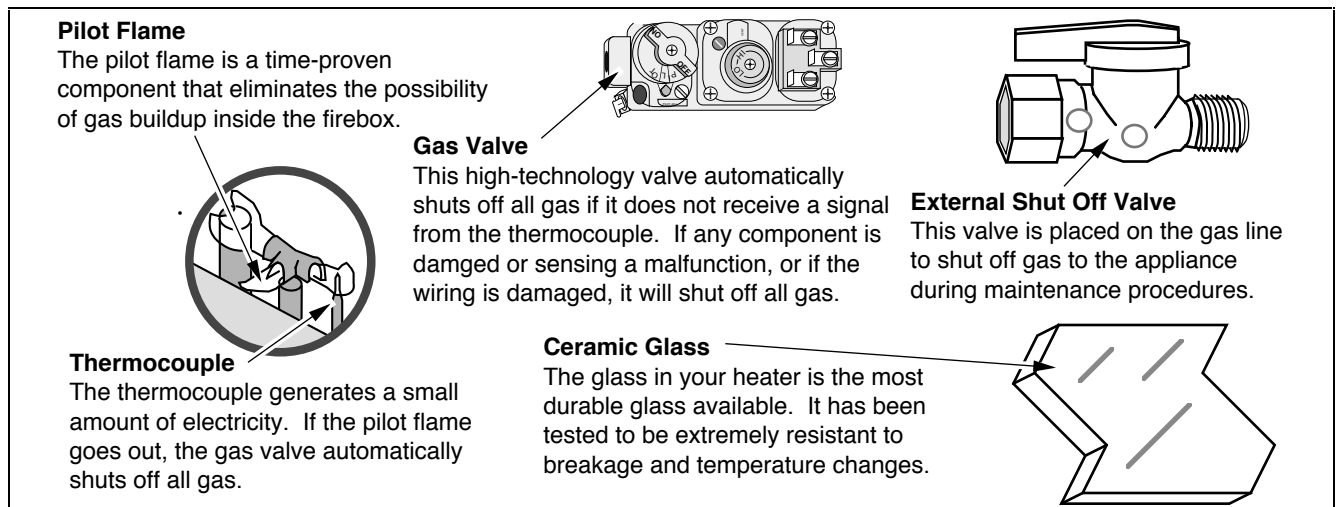

Wiring Diagram

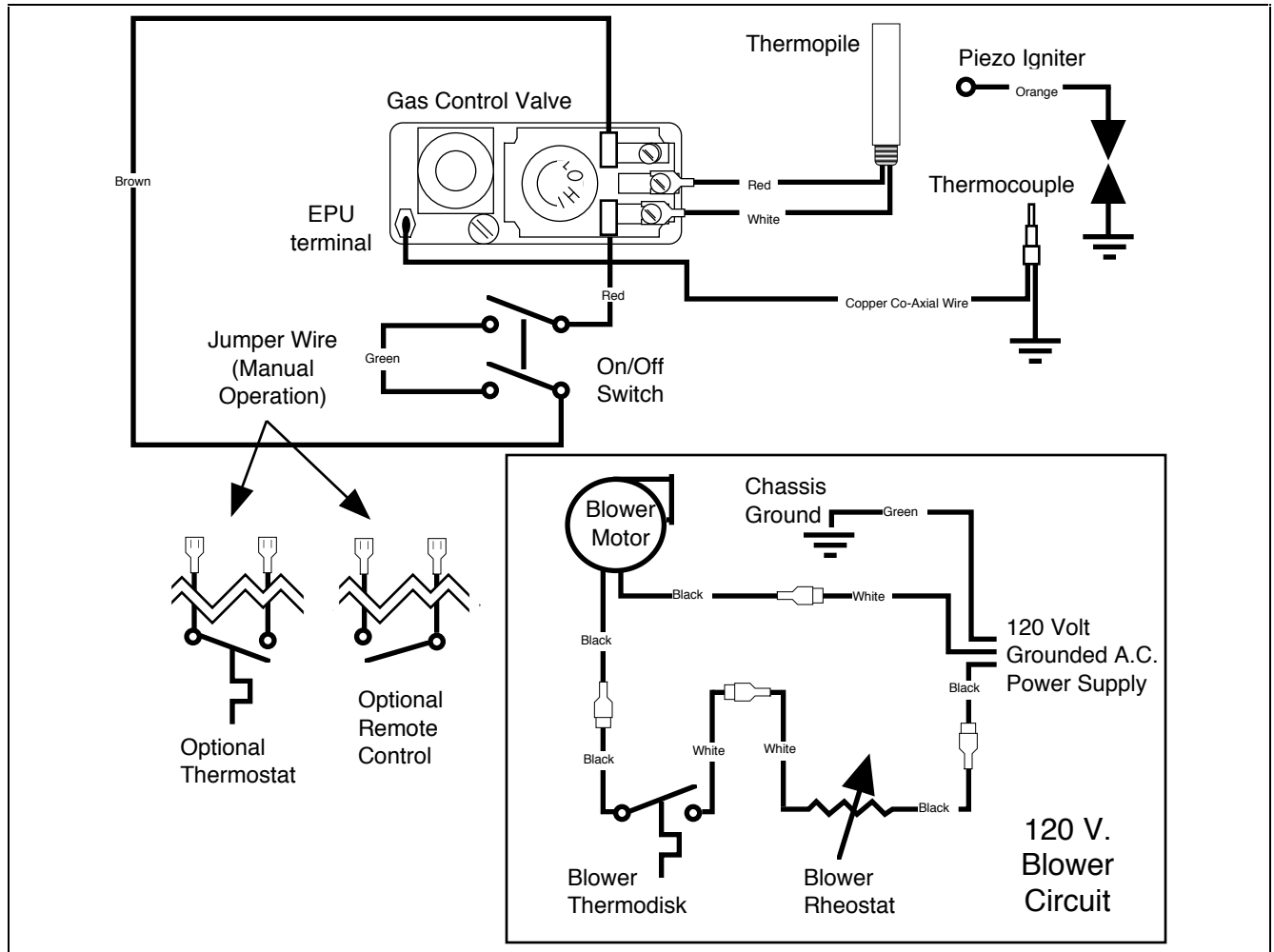

To register your TRAVIS INDUSTRIES, INC. Limited Lifetime Warranty, complete the enclosed warranty card and mail it within ten (10) days of the appliance purchase date to: TRAVIS INDUSTRIES, INC., 10850 117th Place N.E., Kirkland, Washington 98033. TRAVIS INDUSTRIES, INC. warrants the Lopi gas appliance to be defect-free in material and workmanship from the date of purchase as follows:

YEAR 1-COVERAGE: PARTS & LABOR

1. Stove body, component parts & all accessories are covered for one year (ceramic glass covered for thermal breakage only). Cost of any warranted component parts and labor to replace or repair warranted component parts are covered. The cost of the dealer service call or travel time is not covered. Paint & gasketing material are excluded from coverage.
2. One-way freight allowance on pre-authorized repair done at factory is covered.
3. In cases where stove must be removed from home for repairs, a partial cost of re-installation of stove is covered (pre-authorization required).

YEARS 2-5-COVERAGE: PARTS & LABOR

1. Stove body & component parts are covered. Cost of any warranted component parts and labor to replace or repair warranted component parts are covered. The cost of the dealer service call or travel time is not covered. All accessories, gold plating, ceramic glass, paint, ceramic logs, gasketing, electrical components, and valves are excluded from coverage.
2. Any of the above excluded component parts may be purchased at 30% discount off manufacturer's suggested list price (plus any shipping and handling charges from your local dealer).
3. New and replacement accessories not available at discounted prices.
4. One-way freight allowance on pre-authorized repair done at factory is covered.
5. No re-installation coverage.

YEARS 6 & ON-COVERAGE

1. The original purchaser can buy stove component parts at 30% discount off suggested retail (plus any shipping & handling charges from your local dealer) as long as you own the appliance (but a maximum of 5 years after Travis Industries discontinues the designated model).
2. The solid brass door is warranted to not warp, crack or peel for as long as you own the appliance. This warranty does not cover tarnishing of the brass finish. Overfiring or neglect can cause permanent discoloration not covered under warranty (See Owner's Manual for proper care).
3. New and replacement accessories not available at discounted prices.
4. No coverage on stove body, component parts or labor.
5. No freight allowances or re-installation coverage.

CONDITIONS & EXCLUSIONS

1. This new Lopi gas appliance must be installed by a competent authorized gas service contractor. It must be installed and operated at all times in accordance with the installation and operation instructions spelled out in the Owner's Manual. Any alteration, willful abuse, accident, or misuse of the product shall nullify this warranty.
2. This warranty is nontransferable, and is made to the ORIGINAL purchaser, provided that the purchase was made through an authorized Lopi dealer.
3. Discoloration and some minor movement of certain parts is normal and not a defect and, therefore, not covered under warranty. Overfiring of this appliance can cause serious damage not covered under warranty and it is the responsibility of the installer to ensure that the appliance is burning as per rating tag at time of installation.
4. The warranty as outlined within this document does not apply to the chimney components or other Non-Travis accessories used in conjunction with the installation of this product. If in doubt, contact your Authorized Lopi retailer before installation. Travis Industries will not be responsible for...
 - a. Down draft or spillage caused by environmental conditions such as nearby trees, buildings, roof tops, hills or mountains.
 - b. Inadequate ventilation or negative air pressure caused by mechanical systems such as furnaces, fans, clothes dryers, etc.
5. This Warranty is void if:
 - a. The unit has been operated in atmospheres contaminated by chlorine, fluorine or other damaging chemicals.
 - b. The unit is subject to prolonged periods of dampness or condensation.
 - c. Any damage to the unit, combustion chamber, heat exchanger or other components due to water, or weather damage which is the result of, but not limited to, improper chimney/venting installation.
6. Exclusions to this Limited Lifetime Warranty include: injury, loss of use, damage, failure to function due to accident, negligence, misuse, improper installation, alteration or adjustment of the manufacturer's settings of components, lack of proper and regular maintenance, damage incurred while the appliance is in transit, alteration, or act of God.
7. This limited warranty excludes damage caused by normal wear and tear, such as paint discoloration or chipping, worn or torn gasketing, corroded or cracked logs, embers, etc. Also excluded is damage to the unit caused by abuse, improper installation, modification of the unit, drilling of the orifices, or the use of fuel other than that indicated on the gas control valve (natural gas or propane). Damage to the gold finish or solid brass finish caused by fingerprints, scratches, items melted to the face, or other external sources left on the gold or solid brass or from the use of cleaners other than denatured alcohol (gold only) is not covered in this warranty.
8. TRAVIS INDUSTRIES, INC. is free of liability for any damages caused by the appliance, as well as inconvenience expenses and materials. Incidental or consequential damages are not covered by this warranty. In some states, the exclusion of incidental or consequential damage may not apply.
9. This warranty does not cover any loss or damage incurred by the use or removal of any component or apparatus to or from the Lopi gas appliance without the express written permission of TRAVIS INDUSTRIES, INC. and bearing a TRAVIS INDUSTRIES, INC. label of approval.
10. Any statement or representation of Lopi products and their performance contained in Lopi advertising, packaging literature, or printed material is not part of this limited warranty.
11. This warranty is automatically voided if the appliance's serial number has been removed or altered in any way. Only the original purchaser of the Lopi appliance is covered by this warranty. If the appliance is used for commercial purposes, it is excluded from this warranty.
12. No dealer, distributor, or similar person has the authority to represent or warrant Lopi products beyond the terms contained within this warranty. TRAVIS INDUSTRIES, INC. assumes no liability for such warranties or representations.
13. THIS LIMITED LIFETIME WARRANTY IS THE ONLY WARRANTY SUPPLIED BY TRAVIS INDUSTRIES, INC., THE MANUFACTURER OF THE APPLIANCES. ALL OTHER WARRANTIES, WHETHER EXPRESS OR IMPLIED, ARE HEREBY EXPRESSLY DISCLAIMED AND PURCHASER'S RECOURSE IS EXPRESSLY LIMITED TO THE WARRANTIES SET FORTH HEREIN.

IF WARRANTY SERVICE IS NEEDED

1. If you discover a problem that you believe is covered by this warranty, you MUST REPORT it to your Lopi dealer WITHIN 30 DAYS, giving them proof of purchase, the purchase date, and the model name and serial number.
2. Travis Industries has the option of either repairing or replacing the defective component.
3. If your dealer is unable to repair your appliance's defect, he may process a warranty claim through TRAVIS INDUSTRIES, INC., including the name of the dealership where you purchased the appliance, a copy of your receipt showing the date of the appliance's purchase, and the serial number on your appliance. At that time, you will be asked to ship your appliance, freight charges prepaid, to TRAVIS INDUSTRIES, INC. TRAVIS INDUSTRIES, INC., at its option, will repair or replace, free of charge, your Lopi appliance if it is found to be defective in material or workmanship within the time frame stated within this limited warranty. TRAVIS INDUSTRIES, INC. will ship your appliance, freight charges (first five years) prepaid by TRAVIS INDUSTRIES, INC., to your regional distributor, or dealership.
4. Check with your dealer in advance for any costs to you, when arranging a warranty call. Dealers may require you to pay a service or trip charges for any warranty work. This charge can vary from store to store.

The safety label can be found on back of the heater. A copy is shown below.

Tested & Listed by **OMNI** Beaverton, OR. USA
Report No. 028-S-14-5



Heritage Bay
Listed Gas-Fired Direct Vent Wall Furnace



Tested and certified by OMNI-Test, Inc. to the following standards:

USA: ANSI Z21.44-1992 Gas-Fired Gravity and Fan type Direct-Vent Wall Furnace, applicable sections of Z21.11.1-1991 Gas-Fired Vented Room Heaters and UL 307b Gas Burning Heating Appliances for Mobile Homes and Recreational Vehicles.
CANADA: CAN 1-2.19-M81 Gas-Fired Direct-Vent Wall Furnace, CGA IR41 Direct-Vent Gas Fireplace, CGA IR55 additional requirements for Direct-Vent Fireplaces, and CAN/CGA 2.17-M91 "Gas-Fired Appliances for use at High Altitudes".

Must be installed in accordance with all local codes, if any; if not, follow ANSI Z223.1-1992 and NFPA 54(88). Installation in Manufactured or Mobile Homes must conform with: In USA, Manufactured Home Construction and Safety Standard, Title 24 CFR, Part 3280; In Canada, CSA Z240.4 and Gas-Equipped Recreational Vehicles and Mobile Housing. This model is designed to operate on natural gas, or propane (LP). This appliance uses a millivolt-type control system consisting of a gas control valve/regulator, a standing pilot burner assembly, a thermopile, a piezo ignitor, and the ON/OFF switch. THIS UNIT DOES NOT REQUIRE 110 VOLT POWER TO OPERATE. All exhaust gases must be vented outside the structure of the living-area. Combustion air is drawn from outside the living-area structure. This appliance may be installed in Manufactured Housing only after the home is site located.

WARNINGS:

Improper installation, adjustment, alteration, service or maintenance can cause injury or property damage. Refer to the information in the owner's and installation manual provided with this appliance. For assistance or additional information consult a qualified installer, service agency or the gas supplier.
Installation and repair should be performed by a qualified service person. The appliance should be inspected before use and at least annually by a qualified service person. More frequent cleaning may be required where excessive lint from material like carpeting and bedding is present. The control compartment, the burner compartment and all circulating air passageways of the appliance must be kept clean and clear at all times.
Due to high temperatures, the appliance should be located out of traffic and away from furniture and draperies.
This appliance must not be connected to a chimney flue servicing a separate solid fuel burning appliance.
This room heater is a Direct-Vent Gas-Fired appliance. DO NOT burn wood or other material in this heater.
Children and adults should be alerted to the hazards of high surface temperature and should stay away to avoid flesh burns or clothing ignition.
Young children should be carefully supervised at all times when they are in the same room as the appliance.

CAUTION:

All safety screen or guard components removed for servicing, must be replaced prior to operating the appliance.
Clothing or other flammable material should not be placed on or near the appliance.
Risk of electrical shock. Switch the household breaker off or remove fuse before servicing unit.
Use Simpson DURA-VENT direct vent system (Model GS) to vent this appliance to the exterior (direct discharge only without duct connection).

Minimum Clearances to Combustibles			L.P.		N.G.		L.P.		N.G.					
Unit to Sidewall	IN	MM	Input Rate on "HI" (BTU/Hr)	40,000	40,000	Minimum Inlet Pressure (inches W.C.)	11"	5"	Input Rate on "LO" (BTU/Hr)	22,000	19,000	Maximum Inlet Pressure (inches W.C.)	13"	8"
Unit to Backwall	3"	75	Main Burner Orifice (DMS)	#49	#31	Manifold Pressure on "HI" (inches W.C.)	10.5"	3.5"	Manifold Pressure on "LO" (inches W.C.)	2.7"	.9"	This room heater is equipped at the factory for use with natural gas. If conversion to propane (LP) fuel is desired the optional factory conversion kit must be used.		
Unit to Cornerwall	3"	75	Blower Electrical Rating: 115 V., 1.5 Amps, 60 Hz FAN TYPE VENTED CIRCULATOR											
Front of Unit	36"	910												
Alcove Min. Height	60"	1520												
Alcove Max Depth	48"	1220												
Alcove Min Width	43-3/8"	1100												

Manufacture Date: 1997 1998 1999 Jan. Feb. Mar. Apr. May Jun. Jul. Aug. Sep. Oct. Nov. Dec.

Travis Industries, Inc.
10850 117th Pl. N.E. Kirkland, WA 98033

IGN

Thermostat (Part # 99300650)

- ! Do not connect 120 VAC to the gas control valve or wiring of this unit.
- 1 Route the thermostat wire through the back of the right side panel (there is a hole beneath the on/off switch) and attach to the on/off switch (see the illustration below).

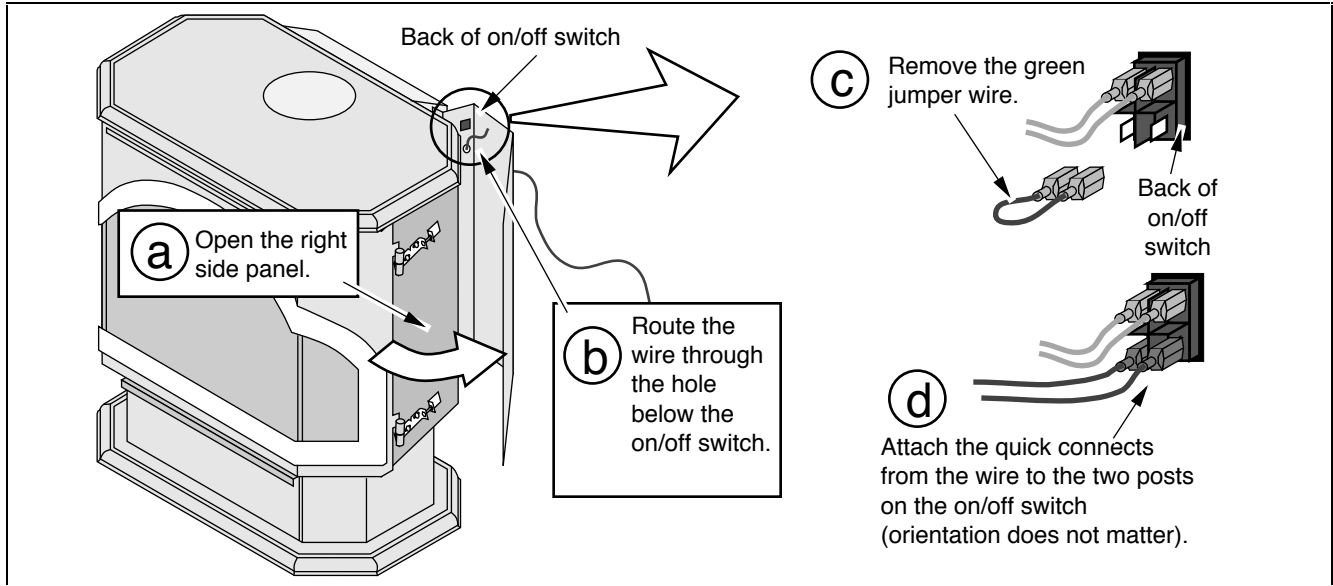

- 2 Pull through all the slack on the wire (you may wish to wrap the wire in electrical tape to prevent damage to the wire). Determine a location for the thermostat that is within range of the 50' length of thermostat wire. It should be centralized in the room and away from the heater. The wire may be routed externally on the wall or behind the wall (preferred).
- 3 Cut the thermostat wire so there is approximately 6" of slack (NOTE: Do not splice thermostat wires together—this leads to too much electrical resistance). Expose 1/2" off each wire of the thermostat wire. Attach the exposed wire to the clips on the back of the thermostat using a screwdriver.

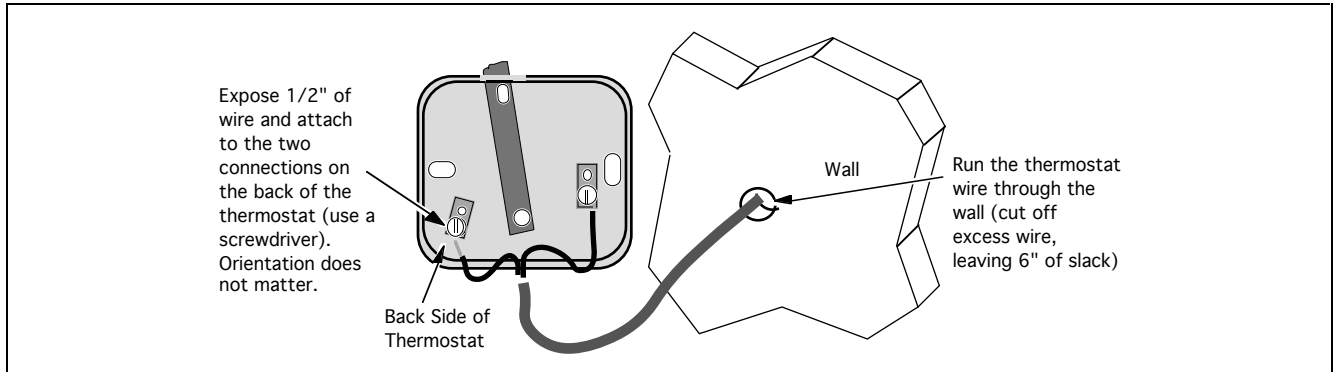

- 4 Pull the cover off the thermostat. Place the thermostat in location and attach it to the wall through the two obround holes (use the appropriate screws for the type of wall it is being attached to). Replace the cover on the thermostat to complete the installation.

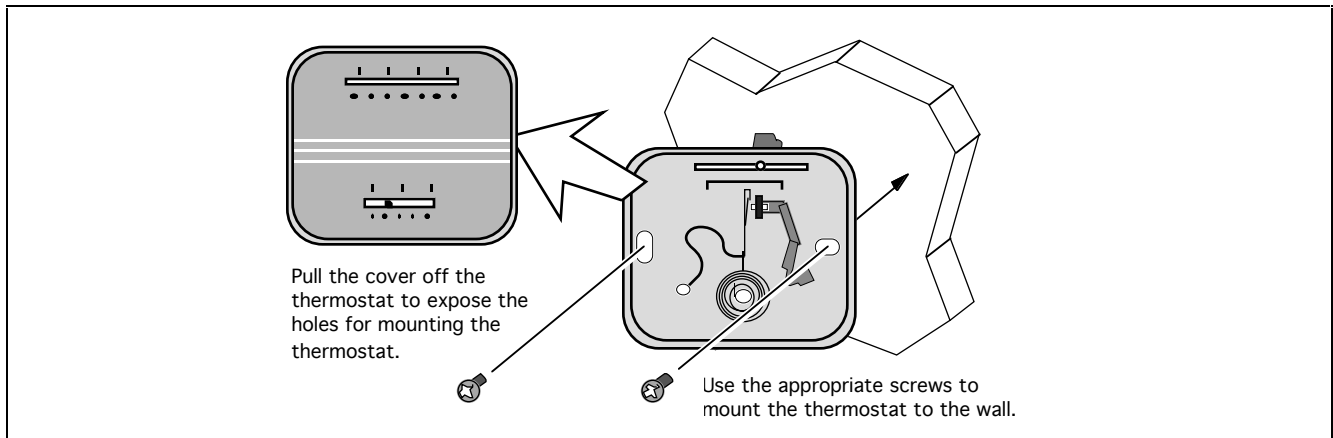

Remote Control Thermostat (Part # 99300652)

- ! Do not connect 120 VAC to the gas control valve or wiring system of this unit.
- 1 Turn the gas control valve to "OFF". Install a standard 9 volt battery into both the remote control receiver and remote control.

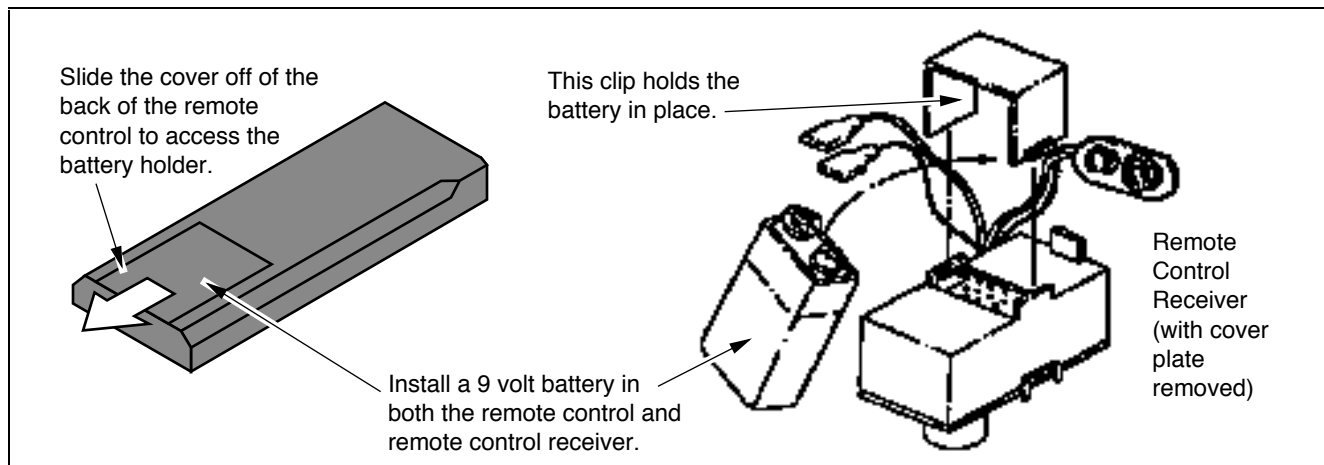

- 2 Route the thermostat wire through the back of the right side panel (there is a hole beneath the on/off switch) and attach to the on/off switch (see the illustration below).

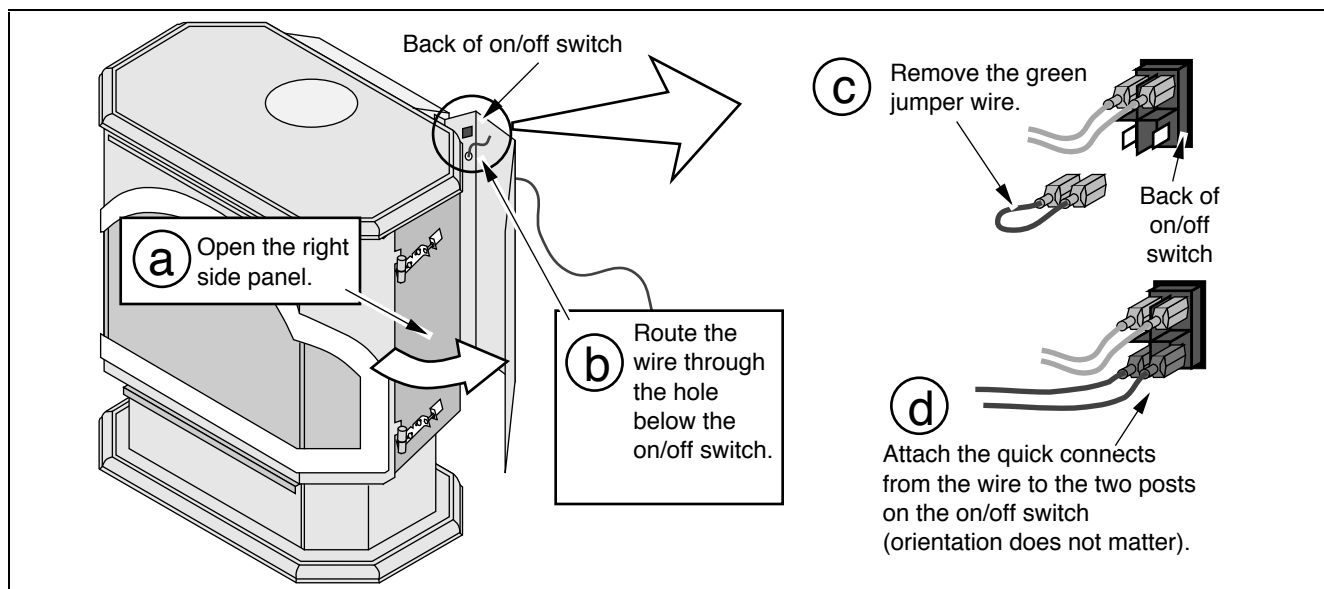

- 3 Pull through all the slack on the wire (you may wish to wrap the wire in electrical tape to prevent damage to the wire).
- 4 The remote receiver may be located to a wall or on the rear panel.

To attach the receiver to a wall:

Determine a location for the receiver. A maximum 50' of wire may be used (use 18 gauge thermostat wire - not supplied). Cut a 1-3/4" wide by 2-1/2" tall hole in the wall for the receiver (see the illustration on the following page). Route the remote wire to the receiver location (wire may be routed behind the wall or externally). Attach quick-connects to the receiver end of the wire and attach to the receiver (orientation does not matter). Attach the receiver and cover plate to the wall (you may be required to use a junction box behind the wall).

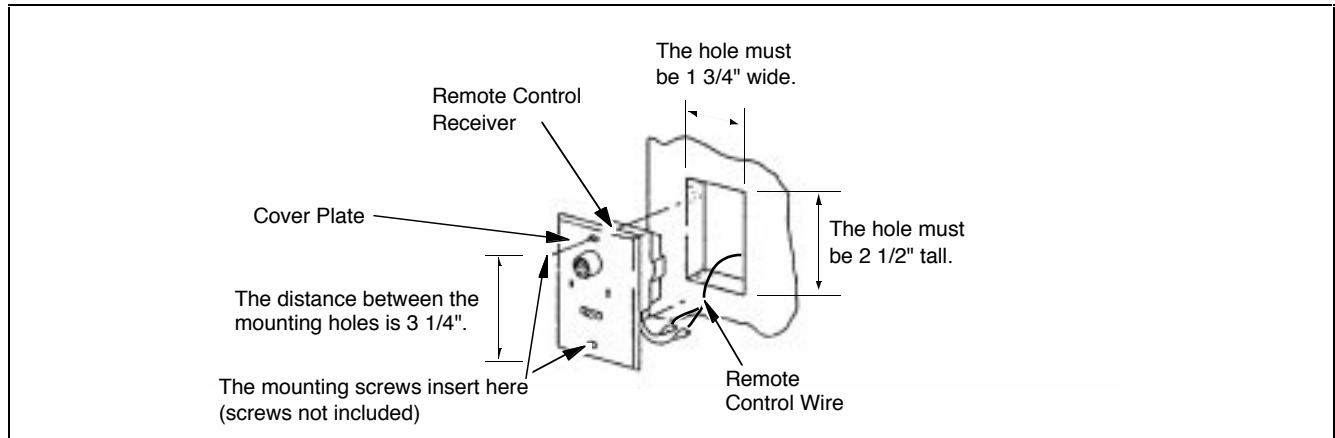

To attach the receiver to the rear panel:

Pull on the remote control receiver wire to remove all slack. Attach the bracket to the remote control receiver with the two 10-24 screws included with the kit (see the illustration below). Position the bracket below the on/off switch and slide the four legs of the bracket into the four slots on the rear panel until the bracket secures. Pull on the remote control receiver wire to remove all slack. Bundle the excess wire together with a lock tie and push the bundle through the rear panel.

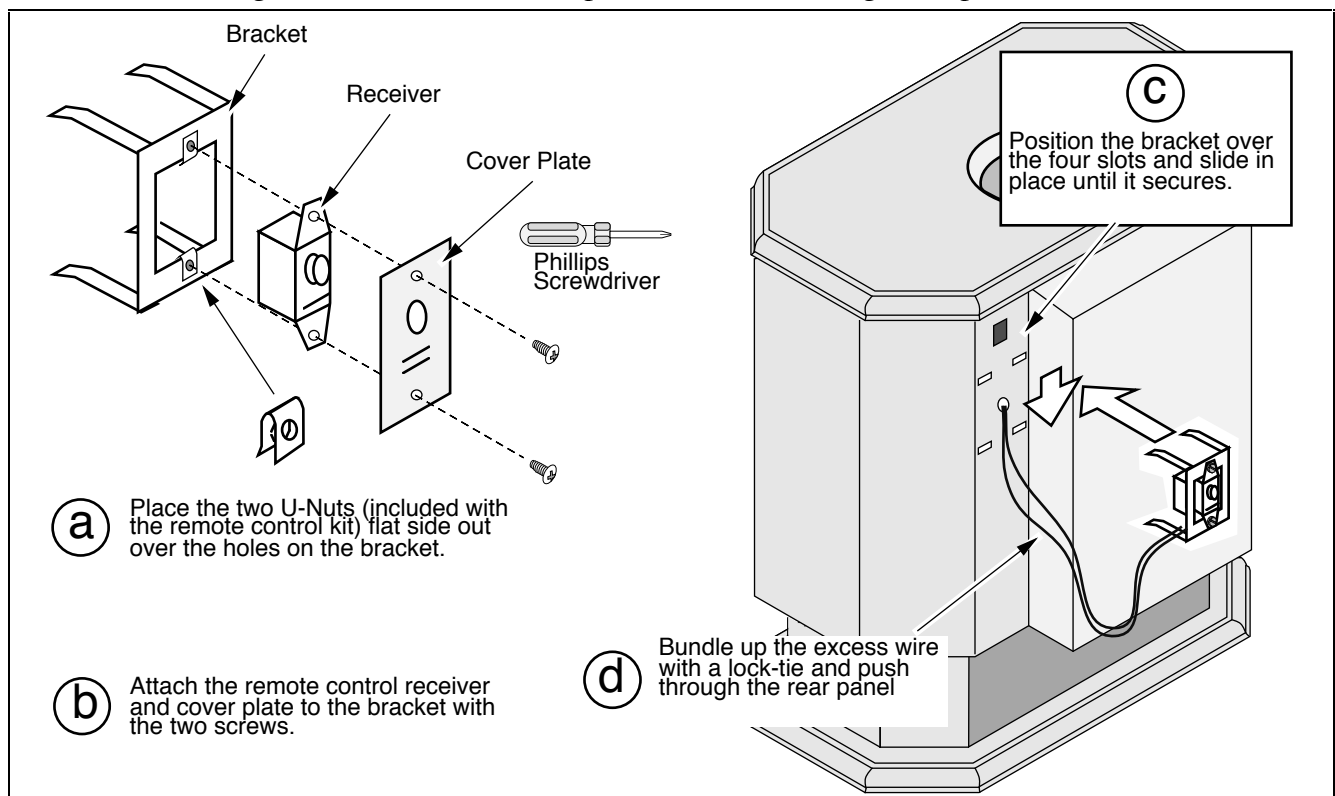

IMPORTANT OPERATIONAL NOTE FOR REMOTE THERMOSTAT USE:

Included with the remote thermostat is a set of instructions that should be given to the homeowner. Please be aware that the remote thermostat has a 1 to 2 minute lag time between the time the thermostat is turned up and the heater turns on.

ADDENDUM #1 Altitude Considerations

This heater has been tested at altitudes ranging from sea level to 8,000 feet (2,400 M). In this testing we have found that the heater, with its standard orifice, burns correctly with just an air shutter adjustment. For information on adjusting the air shutter see page 18 of this manual.

! Failure to adjust the air shutter properly may lead to improper combustion which can create a safety hazard. Please consult your dealer or installer if you suspect an improperly adjusted air shutter.

ADDENDUM #2 Class A Chimney Conversion Kit

Simpson DuraVent provides a conversion kit for those wishing to use an existing wood stove chimney to vent this direct vent stove. The illustration below gives an overview of this type of installation. See the instructions included with the kit for details.

! The conversion kit does not work on interior masonry chimneys.

! Do not exceed the maximum vertical rise (see the section "Approved Vent Configurations" starting on page 9) allowable. Remember to set the restrictor position to the correct position (based upon the vertical rise height - see the chart on page 10).

Chimney Conversion Kit A (# 931)

Metalbestos 6" (150 mm) I.D.
Security Chimneys 6" (150 mm) I.D.
Jackes-Evans 6" (150 mm) I.D.
Hart & Cooley 6" (150 mm) I.D.
Pro-Jet 6" (150 mm) I.D.

Chimney Conversion Kit B (# 932)

Simpson Dura-Vent 6" (150 mm) I.D.
Air-Jet 6" (150 mm) I.D.
Metal-Fab 6" (150 mm) and 7" (175 mm) I.D.
Amer. Metals 6" (150 mm) & 7" (175 mm) I.D.
Metalbestos 7" (175 mm) and 8" (200 mm) I.D.
Jackes-Evans 7" (175 mm) and 8" (200 mm) I.D.
Hart & Cooley 7" (175 mm) and 8" (200 mm) I.D.
Pro-Jet 7" (175 mm) and 8" (200 mm) I.D.
Security Chimneys 8" (200 mm) I.D.

Chimney Conversion Kit C (# 933)

Simpson Dura-Vent 7" (175 mm) and 8" (200 mm) I.D.
American Metals 8" (200 mm) I.D.
Air-Jet 8" (200 mm) I.D.
Metal-Fab 8" (200 mm) I.D.
American Metals 8" (200 mm) I.D.

Each Kit Contains:

Retro Connector
Retro Vertical Top

Additional Equipment:

4" Flex (#711 or U.L. 1777)
Termination (#991)
Co-Axial Sections

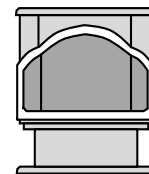
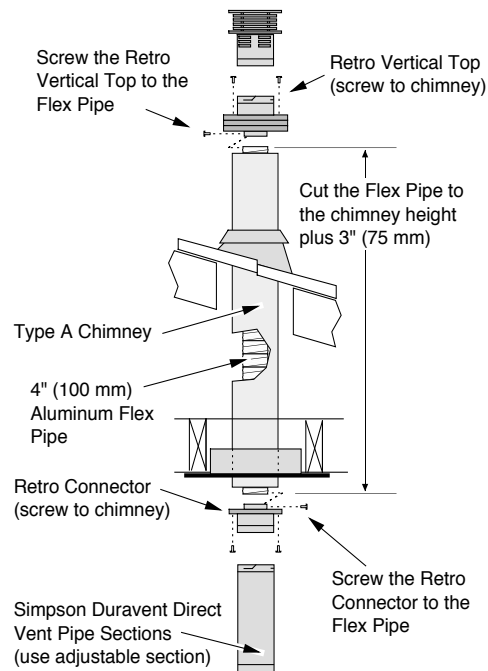

The entire chimney system must be air-tight. Make sure to seal the flashing, clean-out, and thimble connection, and to inspect the chimney.

Make sure the coaxial pipe maintains a 1" clearance to any combustible. The vent must be sealed air-tight.

ADDENDUM #3 Interior Masonry Chimney Conversions

- Follow the requirements and use the equipment listed in the illustration to the right to install this appliance into an interior masonry chimney.
- Maximum vertical rise is 30'
- Minimum vertical rise is 10'
- Use the following restrictor positions:
Position 7 for heights between 10' (3 M) and 24' (7.3 M)
Position 5 for heights between 24' (7.3 M) and 30' (9.1 M)
NOTE: these restrictor positions are based upon lab tests. The ideal restrictor position may vary slightly.

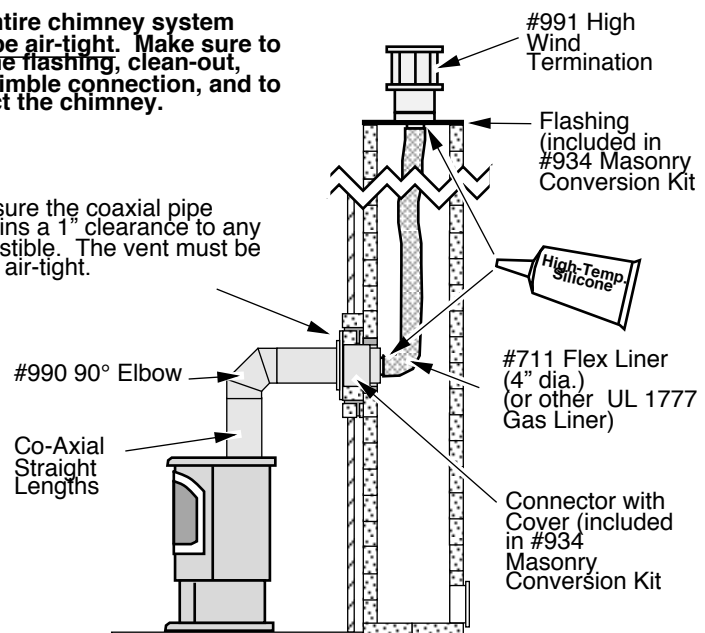

Adjusting the Blower Speed	22	Lifting Flames	18
Adjusting the Flame Height	21	Listing Label (Safety Label)	29
AFUE	5	Log Installation	17
Air Shutter Adjustment	18	Maintaining Your Stove's Appearance	23
Alcoves	7	Natural Gas Verses Propane	2
Altitude Considerations	33	On/Off Operation	21
Amperage (of blower)	5	On/Off Switch (Location)	19
Blower Speed	22	Operating Sounds	22
BTU Output	5	Order of Installation	6
Burn Rate	5	Packing Lists	6
Burner Pan Installation	14	Paint Curing	21
Cap (vent termination)	13	Pilot (starting)	20
Class A Chimney Conversion Kit	33	Pilot Flame (Location)	19
Cleaning Your Heater	23	Pressure (of gas)	7
Clearances	6	Purging Gas Line (with glass off)	17
Condensation	21	Remote Control Thermostat Installation	31
Controls	19	Required Components for Installation	6
Dimensions	5	Restrictor Adjustment	9
Door Opening	15	Safety Label	29
Efficiency	5	Safety Precautions	2
Elbows	9	Silicone Vent Sections	8
Electrical Connection	13	Snorkel Terminations	8
Electrical Specifications	5	Sounds	22
Emissions	5	Starting The Pilot Flame	20
Flame Height	18	Starting the Heater for the First Time	21
Floor Protection Requirements	7	Stove Placement Requirements	7
Fuel	5	Table of Contents	4
Fumes	21	Thermostat Installation	30
Gas Control Valve (Location)	19	Troubleshooting Table	25
Gas Inlet Installation	7	Vent Configurations	9
Gas Leak	See Inst. on Cover	Vent Part #'s	8
Gas Line Connection	7	Vent Requirements	8
Gas Smell	See Inst. on Cover	Vertical Vent Termination Requirements	13
Heating Capacity	5	Warranty	28
High Wind Vertical Terminations	13	Water (on glass - see starting the heater)	21
Horizontal Vent Termination Requirements	13	Wiring Diagram	27
How to Measure Vent Lengths	9	Yearly Service Procedure	23
Installation Options	5		
Installation Preparation	6		
Leaking Gas	See Inst. on Cover		